

# Iwaki Hicera Pump

## V-07AFP06-P (built-in type)

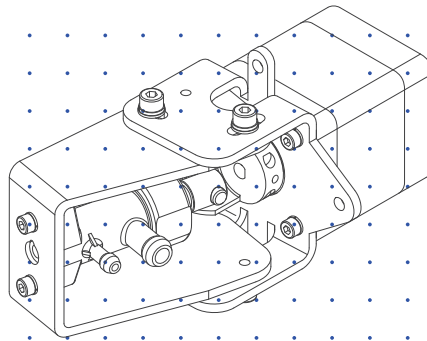

## Instruction manual

Thank you for choosing our product.



Please read through this instruction manual before use.

This instruction manual describes important precautions and instructions for the product. Always keep it on hand for quick reference.

## Order confirmation

Open the package and check that the product conforms to your order. If any problem or inconsistency is found, immediately contact your distributor.

### **a. Check if the delivery is correct.**

Check the nameplate to see if the information such as model codes is as ordered.

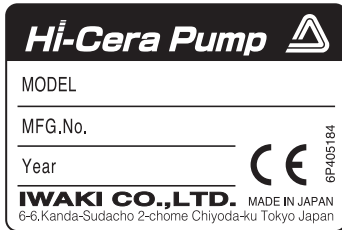

Europe

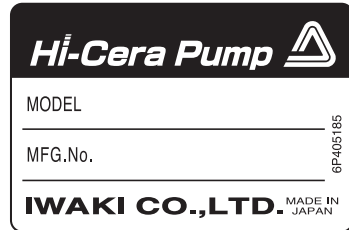

Other areas

\*The CE marking on our product(s) is for us to market the product(s) into the European market, however, the CE marking does not ensure any safety or conformity of the product(s) outside the European market.

When the pump is incorporated into the equipment marketed in the European market, such equipment must meet all the requirements of applicable directives. In such a case, any person who places the equipment on the market must carry a CE mark on the equipment as a manufacturer.

### **b. Check if the delivery is damaged or deformed.**

Check for transit damage and loose bolts.

# Contents

<b>Order confirmation .....</b>	<b>2</b>
<i>Safety instructions .....</i>	<i>5</i>
<b>Warning.....</b>	<b>6</b>
<b>Caution.....</b>	<b>7</b>
<b>Precautions for use .....</b>	<b>10</b>
<i>Overview.....</i>	<i>13</i>
<b>Introduction.....</b>	<b>13</b>
<b>Part names.....</b>	<b>14</b>
Pump.....	14
<b>Identification codes.....</b>	<b>15</b>
<i>Installation .....</i>	<i>16</i>
<b>Pump mounting.....</b>	<b>16</b>
<b>Pipework .....</b>	<b>18</b>
Tube connection .....	18
<b>Wiring.....</b>	<b>19</b>
Lead wires .....	19
Motor.....	20
Motor specification .....	20
Wiring diagram .....	20
Motor connector specification .....	20
Sensor .....	21
Motor rotation detection .....	21
Wiring diagram .....	21
Sensor connector specification .....	21

<i>Operation</i> .....	22
------------------------	----

<b>Operation</b> .....	<b>22</b>
Starting the pump .....	22
Stoppage .....	23
Preventative measures against seizing .....	24
Speed of acceleration .....	24
Inching .....	25
Restart at the time of motor step-out .....	25

<i>Maintenance</i> .....	26
--------------------------	----

<b>Troubleshooting</b> .....	<b>26</b>
<b>Inspection</b> .....	<b>28</b>
Daily inspection .....	28
<b>Wear part replacement</b> .....	<b>29</b>
Wear part list.....	29
Before service is performed .....	30
Pump head .....	30
Disassembly .....	31
Assembly .....	32
<b>Specifications/Outer dimensions</b> .....	<b>33</b>
Specifications .....	33
Pump unit .....	33
Stepping motor .....	33
Hole IC .....	33
Outer dimensions.....	34
EC DECLARATION OF CONFORMITY.....	35

# Safety instructions

Read through this section before use. This section describes important information for you to prevent personal injury or property damage.

## ■ Symbols

In this instruction manual, the degree of risk caused by incorrect use is noted with the following symbols. Please pay attention to the information associated with the symbols.



**WARNING**

Indicates mishandling could lead to a fatal or serious accident.



**CAUTION**

Indicates mishandling could lead to personal injury or property damage.

A symbol accompanies each precaution, suggesting the use of "Caution", "Prohibited actions" or specific "Requirements".

### Caution marks



Caution



Electrical shock

### Prohibited mark



Prohibited



Do not rework or alter

### Requirement mark



Requirement



Wear protection



Grounding



## Export Restrictions

Technical information contained in this instruction manual might be treated as controlled technology in your countries, due to agreements in international regime for export control.

Please be reminded that export license/permission could be required when this manual is provided, due to export control regulations of your country.

## WARNING

---

### Turn off power before service

Risk of electrical shock. Be sure to turn off power to stop the pump and related devices before service is performed.



---

### Stop operation

If you notice any abnormal or dangerous conditions, suspend operation immediately and inspect/solve problems.



---

### Do not use the pump in any condition other than its intended purpose

The use of the pump in any conditions other than those clearly specified may result in failure or injury. Use this product in specified conditions only.



---

### Do not modify the pump

Alterations to the pump carries a high degree of risk. It is not the manufacturer's responsibility for any failure or injury resulting from alterations to the pump.



---

### Wear protective clothing

Always wear protective clothing such as an eye protection, chemical resistant gloves, a mask and a face shield during disassembly, assembly or maintenance work. The specific solution will dictate the degree of protection. Refer to MSDS precautions from the solution supplier.



---

### Do not damage the power cable

Do not pull, knot, or crush the power cable. Damage to the power cable could lead to a fire or electrical shock if cut or broken.



---

### Do not operate the pump in a flammable atmosphere

Do not place explosive or flammable material near the pump.



**! CAUTION****Qualified personnel only**

The pump should be handled or operated by qualified personnel with a full understanding of the pump. Any person not familiar with the product should not take part in the operation or maintenance of the pump.



Requirement

**Use specified power only**

Do not apply power other than that specified on the nameplate. Otherwise, failure or fire may result. Ensure the pump is properly grounded.



Prohibited

**Do not run pump dry**

Do not run pump dry for more than 3 minutes (even when the pump runs for degassing). Otherwise, friction heat may build up and the plunger may seize in the cylinder. Optimise your system and eliminate the possibility of dry running.



Caution

**Do not close a suction or a discharge line in operation**

Closed-suction/-discharge operation may damage the pump and piping.



Prohibited

**Keep electric parts and wiring dry**

Risk of fire or electric shock. Install the pump where it can be kept dry.



Prohibited

**Ventilation**

Fumes or vapours can be hazardous with certain solutions. Ensure proper ventilation at the operation site.



Caution

**Do not install or store the pump:**

- In a flammable atmosphere.
- In a dusty/humid environment.
- Where ambient temperature can exceed 0-60°C.
- In direct sunlight or wind & rain.



Prohibited

---

### Electromagnetic precautions

This product is not protected against an electromagnetic field. Take appropriate measures as necessary.



Requirement

---

### Spill precautions

Ensure protection and containment of solution in the event of plumbing or pump damage (secondary containment).



Requirement

---

### Do not use the pump in a wet location

The pump is not waterproof. Use of the pump in wet or extremely humid locations could lead to electric shock or short circuit.



Prohibited

---

### Grounding

Risk of electrical shock! Always properly ground the pump. Conform to local electric codes.



Grounding

---

### Install a GFCI (earth leakage breaker)

An electrical failure of the pump may adversely affect other devices on the same line. Purchase and install a GFCI (earth leakage breaker) separately.



Electrical shock

---

### Preventative maintenance

Follow instructions in this manual for replacement of wear parts. Do not disassemble the pump beyond the extent of the instructions.



Requirement

---

### Do not use a damaged pump

Use of a damaged pump could lead to an electric shock or death.



Prohibited

---

### Disposal of a used pump

Dispose of any used or damaged pump in accordance with local rules and regulations. If necessary, consult a licensed industrial waste disposal company.



Requirement



---

### Static electricity precautions

Take measures against static electricity when working around or with electronics, or a motor or an electric device may be damaged.



---

### Magnetic field precautions

A magnet is mounted in the pump and its magnetic force may adversely affect magnetic disks/cards or wrist watches. Do not bring them close to the pump.



---

### Install a relief valve

Install a relief valve to depressurize a discharge line if its pressure resistance will not bear the possible highest pressure. The set pressure of the relief valve must not exceed the maximum allowable pressure of the discharge line.



---

### Risk of burning

Do not touch the pump or pipe with bare hands. The surface temperature of the pump or pipe rises high along with liquid temperature in or right after operation.



## Precautions for use

- Electrical work should be performed by a qualified electrician. Otherwise, personal injury or property damage could result.
- Do not install the pump:
  - In a flammable atmosphere.
  - In a dusty/humid place.
  - In direct sunlight or wind & rain.
  - Where ambient temperature can exceed 0-60°C.
- Anchor the pump with four M4 bolts so it doesn't vibrate. Mount vibration isolators to each pump foot as necessary.
- When two or more pumps are installed together, vibration may be significant, resulting in poor performance or failure. Select a solid foundation (concrete) and fasten anchor bolts securely to prevent vibration during operation.
- Allow sufficient space around the pump for easy access and maintenance.
- Install the pump as close to the supply tank as possible.
- Observe the maximum suction lift of 1 meter (with clean water). Note it varies with liquid characteristics.
- Liquid viscosity over 10mPa•s will not allow operation at a normal (/high) pump speed. It must be reduced to an optimal speed. Contact us for detail.
- Delivery of slurry is not allowed, or the pump may break in a short period of time.



Caution

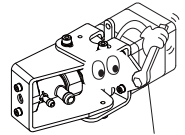
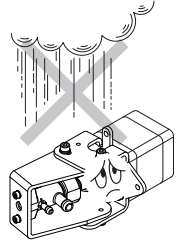

Vibration isolator



Caution



Caution



Caution



Caution



Caution



Caution

- For the operation with adhesive liquid including dialysis solution, take the following measures for the prevention of a stuck plunger:
  - a. In operation, flush out the pump head with cleaning port using clean water or cleaning liquid.
  - b. After operation, disassemble and clean with the liquid. Use of tap water for flushing is not allowed.



Requirement

- Take the following measures in addition to the above, especially after sending dialysis solution.

- a. To make sure the plunger is free from being stuck, flush out the pump head with cleaning port using citric acid or acetic acid at 10-40°C once every 50 hours of operation.
- b. To make sure the pump head is sterilized, flush out with cleaning port using hot water at 80-95°C as necessary.



Requirement

- Use care handling the pump. Do not drop. An impact may affect pump performance. Do not use a pump that has been damaged to avoid the risk of electrical damage or shock.

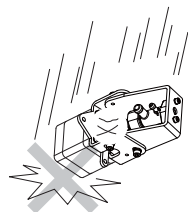

- Observe the allowable liquid temperature range of 10-40°C.



Caution

- Do not operate the pump while wet with solution or water. Failure or injury may result. Immediately dry off the pump if it gets wet.



Caution

- Commissioning is required in order to expel air from tubing.



Caution

- Solution in the discharge line may be under pressure. Release the pressure from the discharge line before disconnecting plumbing or disassembly of the pump to avoid solution spray.



Requirement

- Wear protective clothing when handling or working with pumps. Consult solution MSDS for appropriate precautions. Do not come into contact with residual solution.



- Do not allow foreign matters to enter the pump. Clogging may cause the plunger to be locked or damaged, hindering a liquid circulation.



- Do not clean the pump or nameplate with a solvent such as benzine or thinner. This may discolour the pump or erase printing. Use a dry or damp cloth or a neutral detergent.



- Always stop the pump with the plunger extended to the full, so the cylinder will not retain liquid in it.



- Observe the maximum allowable discharge pressure of 200kPa, or the pump may be damaged.



# Overview

Pump characteristics, features and part names are described in this section.

## Introduction

### Pump structure & Operating principle

The Hicera pump is a metering pump with fine ceramic wet ends such as a plunger, a cylinder and other related parts.

The plunger reciprocates and rotates in the cylinder where liquid is taken in from a suction line and then delivered to a discharge line.

#### Principle of operation

In the suction process, the rotating plunger contracts to take in liquid into the cylinder from a suction line as the duct on the plunger passes the inlet.

In the discharge process, the rotating plunger extends to let out liquid from the cylinder to a discharge line as the duct on the plunger passes the outlet.

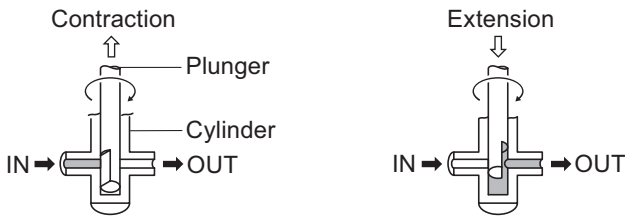

- ⇨: Plunger reciprocation
- : Plunger rotation
- ➡: Flow direction

## Part names

### Pump

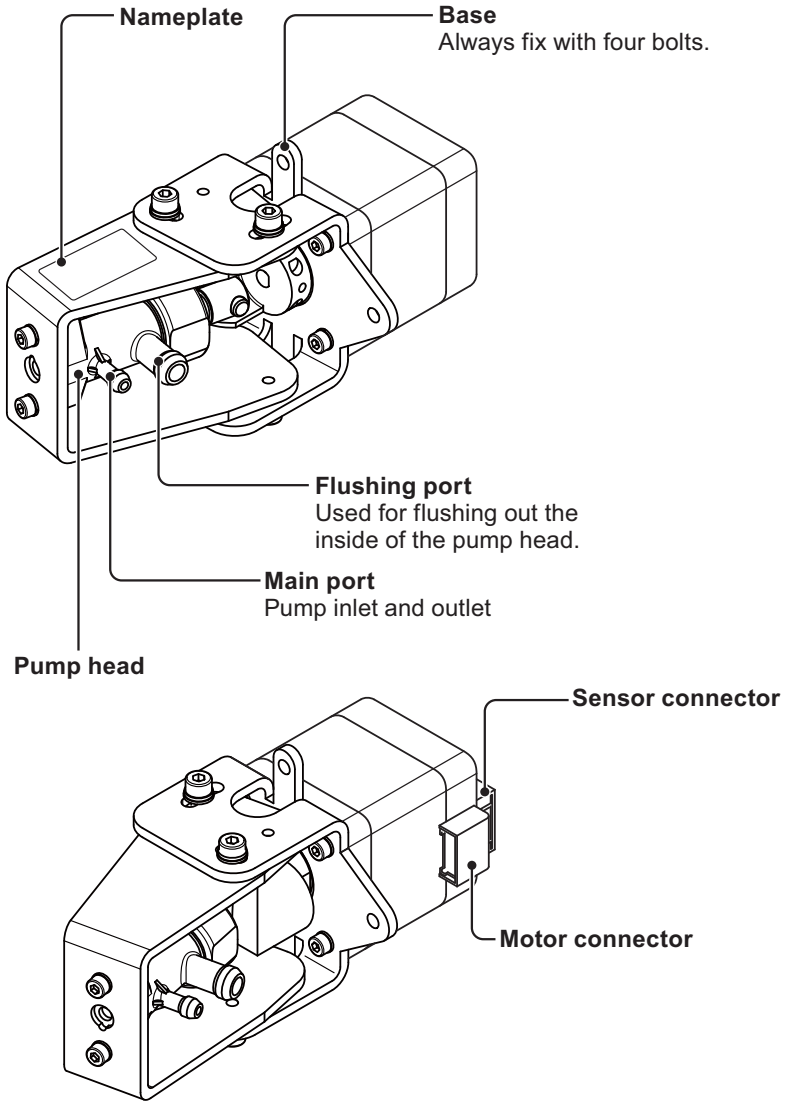

## Identification codes

*The model codes represent the following information.*

V - 07 A F P 0 6 - P 01  
a b c d e f g h i

**a. Series name**

V: Hicera pump

**b. Plunger diameter**

07:  $\varnothing$ 7mm

**c. Plunger/Cylinder**

A:  $\text{Al}_2\text{O}_3/\text{Al}_2\text{O}_3$

**d. Wet end materials**

F: PVDF

**e. Flushing port**

P: Pumps with flushing ports

**f. Joint**

0: Special design

**g. Motor power voltage**

6: 24VDC

**h. Motor specification**

P: Stepping motor

**i. Discharge capacity per shot**

01: 0.1mL/shot

02: 0.2mL/shot

# Installation

*Installation of the pump, tubing and wiring are described in this section.*

## **!** Observe the following points

- Risk of electrical shock. Be sure to turn off power to stop the pump and related devices before service is performed.
- If you notice any abnormal or dangerous conditions, suspend operation immediately and inspect/solve problems.
- Do not place explosive or flammable material near the pump.
- Do not use a damaged pump. Use of a damaged pump could lead to an electric shock or death.
- This dedicated pump is designed for built-in application only. Its rotating parts are not protected. Provide a safety protection to your host machine as necessary.

## Pump mounting

*Select an installation location and mount the pump.*

### **Necessary tools**

- Four M4 bolts (pump mounting)
- Adjustable wrench or spanner

### **1 Select a suitable place.**

See page 10, the "Precautions for use" section, and select the best installation location.

Install the pump as close to the supply tank as possible.

#### **NOTE**

Observe the maximum suction lift of 1 meter (with clean water). Note it varies with liquid characteristics.



## 2 Select a mounting direction.

### NOTE

Mounting directions are limited. Any direction other than the following examples may cause performance reduction or failure.

- a. Laid in a horizontal position on its side. There is no limitation on the inlet and outlet directions.

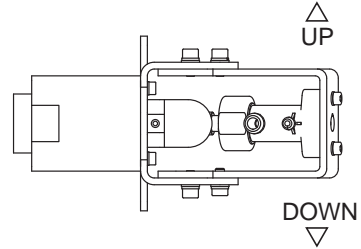

- b. Laid in a horizontal position on its back. The inlet must be directed downwards to take in and deliver liquid upwards.

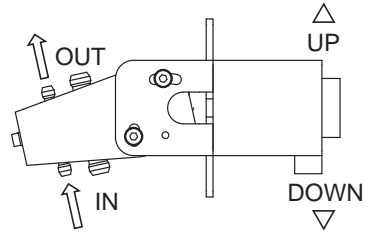

- c. Laid in a vertical position on its head. The inlet must be directed downwards to take in and deliver liquid upwards.

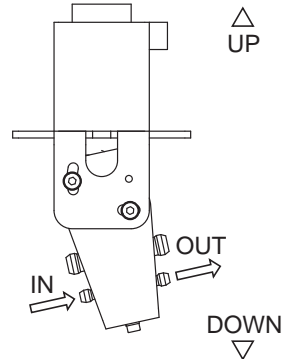

## 3 Anchor the pump by the M4 bolts.

Be sure to fix the pump at four points.

### NOTE

Install vibration isolators to each pump foot as necessary.

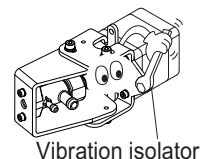

## ***Tube connection***

Observe the following points for plumbing.

- Have tubing length shortest with the minimum number of bends in order to reduce pipe resistance.
- The inlet and outlet ports should be completely sealed for the prevention of air ingress into a flow line. An imperfect suction line connection entrains air and reduces performance.
- Select proper tube sizes for the inlet/outlet ports and the flushing ports. A tube should be pressure-/corrosion-resistant to specified operating conditions.
- Use a tube clamp to secure tubes to the ports so that it will not come off under pressure or by an external force.
- Install a shutoff valve in a suction line when the pump is installed in a flooded suction system.
- The PVDF fitting may break. Do not use excessive force.

### **1 Connect tubes into the inlet and outlet.**

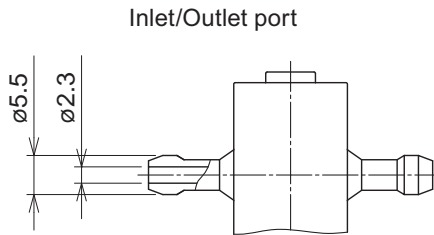

### **2 Connect tubes into the flushing ports.**

Use a proper tube size to the fitting

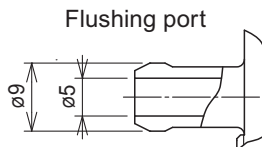

*A driver and PLC/controller are necessary for pump operation. Purchase separately.*

### **!** Observe the following points

- Electrical work should be performed by a qualified electrician. Always observe applicable codes or regulations.
- Do not perform wiring work while electric power is ON. Otherwise, an electrical shock or a short circuit may result. Be sure to turn off the power before wiring work.

### ***Lead wires***

---

*Use two UL1007 AWG #24 lead wires. One is for motor wiring and the other is for sensor wiring.*

## Motor

This pump is equipped with an 2-phase bipolar stepper motor. Select and electrically connect a suitable driver according to the motor specification below.

### ■ Motor specification

Driving method	Two bipolar constant current drive
Power voltage range	24VDC±10%
Motor current	0.69A/phase (0-PEAK)
Rated microstep	1/16
Rated pull-out torque	150mN•m or more (at 300rpm)

### NOTE

Keep the motor surface temperature 80°C or below. Or the stepper motor may break or the service life may be shorten.

### ■ Wiring diagram

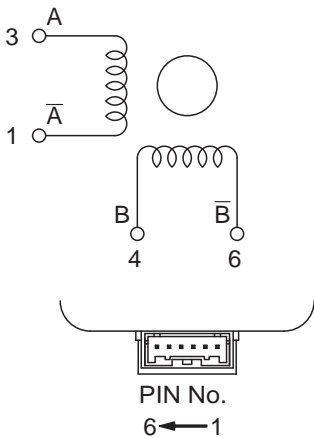

STEP \ PIN No. Ph	3 (A)	4 (B)	1 (Ā)	6 (B̄)
1	+	+	-	-
2	-	+	+	-
3	-	-	+	+
4	+	-	-	+

### ■ Motor connector specification

	Motor	User PLC/Controller
Maker	J.S.T. Mfg. Co.,Ltd.	J.S.T. Mfg. Co.,Ltd.
Housing	B06B-PASK	PAP-06V-S
Contact (post)	-	SPHD-001T-P0.5

# Sensor

## ■ Motor rotation detection

The rotation detector monitors motor rotation and transmits a signal for about 9° in the detection range below.

Detection range with operation in a clockwise rotation (seen from the pump head side) : 27-63°

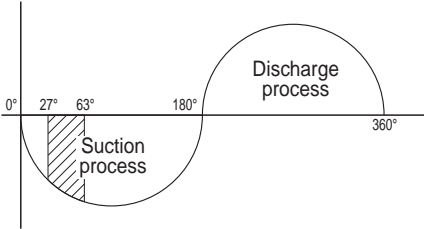

Detection range with operation in a counter clockwise rotation (seen from the pump head side) : 297-333°

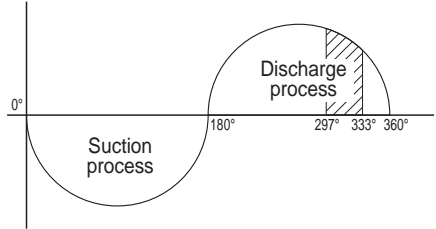

## ■ Wiring diagram

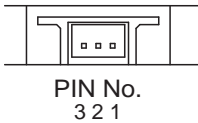

PIN No.	SIGNAL
1	GND
2	OUT
3	Vcc

## ■ Sensor connector specification

	Sensor	User PLC/Controller
Maker	J.S.T. Mfg. Co.,Ltd.	J.S.T. Mfg. Co.,Ltd.
Housing	S3B-PH-SM4-TB	PHR-3
Contact (post)	-	SPH-002T-P0.5S

# Operation

The pump becomes ready after pipework and wiring is completed.

## Operation

Do not run pump dry or run it with a discharge valve or a suction valve closed for more than 3 minutes.

### Starting the pump

- 1 Check if plumbing and wiring are done correctly.
- 2 Check the spec label to see if the power supply voltage is correct.
- 3 Fully open both suction and discharge valves.
- 4 Set the speed of acceleration.  
See page 24 for detail.
- 5 Prime and run the pump for testing.

Check if a flow direction is correct.

\*In a clockwise rotation (seen from the pump head), liquid flows in the direction of "a".

\*In a counter clockwise rotation (seen from the pump head), liquid flows in the direction of "b".

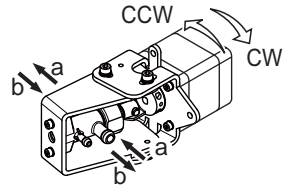

---

**6 Check liquid flows without a hitch.**

If you notice any abnormality, turn off power and investigate/solve root causes. Refer to the troubleshooting section.

---

**7 Make sure air has been completely expelled from the pump and a tubing system.**

If not, an accurate flow can not be obtained.

---

**8 Adjust the number of pulse signals to meet a target flow rate.**

Discharge capacity per minute is determined by the formula of:

$$\text{Liquid volume per shot (ml/shot)} \times \text{pump rotation speed (rpm)}$$

---

**NOTE**

- The enclosure of your equipment in which the pump is built may resonate with a pump operating noise in some rpm range.
  - A slight leak may occur in operation from the plunger depending on individual difference. The leak is allowed as long as the pump meets the specified performance.
- 

---

**Stoppage**

---

**1 Flush the pump head with clean water every time sticky or settling liquid is delivered.**

**2 Flush the pump head with clean water before a long period (one week or more) of stoppage.**

---

## ***Preventative measures against seizing***

---

Determine the speed acceleration time and perform inching to keep the optimal pump performance.

### **■ Speed of acceleration**

In order to eliminate the possibility of step-out, always start or stop the motor in a start/stop region (1600pps or below).

Because the maximum allowable start/stop frequency reduces as starting torque (current setting) gets lower, motor acceleration to a specified rate (above 1600pps) with no acceleration time may often trigger motor step-out.

When a stepping motor driver is set to 1/16 microstep and 0.69A/phase (0-PEAK) and a specified rate is 16000pps, for example, start the motor at 1600pps or below and take at least 0.15sec for acceleration to 16000pps.

Note the acceleration time required may change with operating conditions such as pipe resistance and other factors. Determine an optimal acceleration time according to your system.

### **Recommendable setting (operation above 1600pps)**

Number of pulses at start (start/stop region): 1600pps or below (30rpm or below)

Speed of acceleration to 16000pps : 0.15sec or more

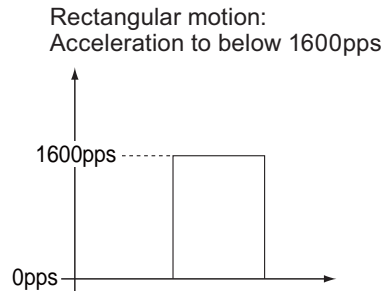
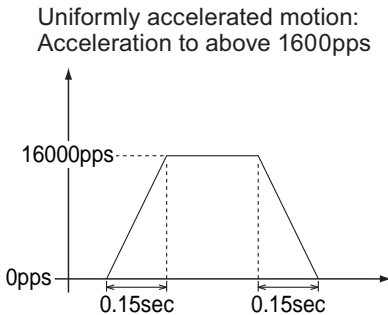



■ **Inching**

Delivery of some liquid, which forms precipitate such as silica in between the cylinder and the plunger, may adversely affect the plunger motion. Rotate the motor one revolution in negative and then positive rotation (inching) per hour while your system is left stopped. Inching will keep a plunger wet in the cylinder and will prevent plunger lock. Be sure to set the optimal acceleration time. See page 24, the "Speed of acceleration" section, for detail.

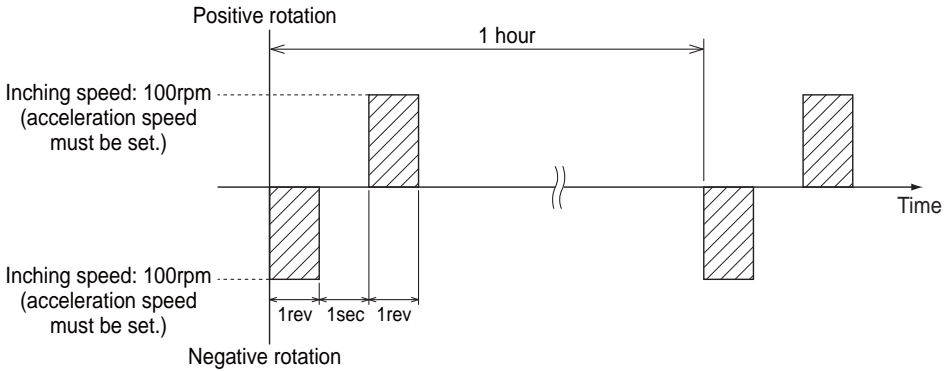

■ **Restart at the time of motor step-out**

In case the stepping motor has stepped out, stop sending the pulse signal once and then just restart the motor in the start/stop region.

**NOTE**

If the plunger has stuck in the cylinder, disassemble and clean the inside of the pump head. See page 31 for detail.

# Maintenance

*Troubleshooting, inspection, wear part replacement and specifications are described in this section.*

## Important

- Follow instructions in this manual for replacement of wear parts. Do not disassemble the pump beyond the extent of the instructions.
- Always wear protective clothing such as an eye protection, chemical resistant gloves, a mask and a face shield during disassembly, assembly or maintenance work. The specific solution will dictate the degree of protection. Refer to MSDS precautions from the solution supplier.
- Risk of electrical shock. Be sure to turn off power to stop the pump and related devices before service is performed.

## Troubleshooting

*First check the following points. If the following measures do not help remove problems, contact us or your nearest distributor.*

States	Possible causes	Solutions
The pump does not start to run.	Power is not supplied.	• Supply power.
	Wrong wiring or disconnection	• Correct wiring.
	Plunger lock due to crystallization*	• Take apart the pump head and clean wet ends.
	High specific gravity or high viscosity	• Use an applicable pump model.
	Clogging due to foreign matters	• Remove foreign matters. Replace parts if damaged.
	Faulty driver	• Replace as necessary.
The pump does not deliver liquid during operation.	A suction or a discharge line is closed during operation.	• Open both the suction and discharge lines.
	A supply tank is empty.	• Replenish the supply tank.
	The motor is rotating the other way around.	• Correct wiring.
	Wrong tubing or poor connection	• Check and fix tubing.

States	Possible causes	Solutions
The flow rate is too small.	Air ingress through a tube joint	• Keep tube joints air-tight.
	Development of cavitation	• Reduce a motor rpm, liquid temperature, and tubing resistance.
	Pump rotation speed is too low.	• Increase a rotation speed.
	A suction line is crushed.	• Replace as necessary.
Significant vibration or noise.	Discharge pressure is too high.	• Reduce discharge pressure.
	A suction or a discharge line is closed during operation.	• Open both the suction and discharge lines.
	Air ingress through a tube joint	• Keep tube joints air-tight.
	Development of cavitation	• Reduce a motor rpm, liquid temperature, and tubing resistance.
	A supply tank is empty.*	• Replenish the supply tank.
	Anchor bolts are loose.*	• Fasten anchor bolts.
Liquid leaks.	Sympathetic vibration with the pump and other parts of system	• Fit vibration isolators to each foot.
	Discharge pressure is too high.	• Reduce discharge pressure.
	A lip seal is crushed.	• Replace as necessary.
Pump stops.	The cap nut got loose.	• Retighten the nut to 1.5N•m
	Wrong wiring or disconnection	• Correct wiring.
	Plunger lock due to crystallization	• Take apart the pump head and clean wet ends.
	High specific gravity or high viscosity	• Use an applicable pump model.
	Clogging due to foreign matters	• Remove foreign matters. Replace parts if damaged.
	Discharge pressure is too high.	• Reduce discharge pressure.
Faulty driver	• Replace as necessary.	

The causes with the \* mark are typical cases of failure.

## Inspection

Perform daily inspection to keep pump performance and safety.

### **Daily inspection**

Check the following points. If you notice any abnormal or dangerous conditions, suspend operation immediately and inspect/solve problems according to "Troubleshooting".

When wear parts come to the life limit, replace them with new ones. Contact us or your nearest distributor for detail.

No.	States	Points to be checked	How to check
1	Pumping	• If liquid is pumped.	Flow meter or visual inspection
		• If a discharge and a suction pressure are normal.	Pressure gauge
2	Noise and Vibration	• If abnormal noise or vibration occurs. They are signs of abnormal operation. Mount vibration isolators to each pump foot to reduce noise or oscillation as necessary.	Visual or audio inspection
3	Air ingress from pump head joints and a suction line	• If pumped liquid includes air bubbles. Check the joints/line for leakage and retighten as necessary.	Visual inspection
4	High surface temperature of the pump and the motor	• If the motor surface temperature is 100°C or below (the max ambient temperature plus 40°C at a maximum). Note the pump surface temperature gets high or low along with liquid temperature.	Touch or use a thermometer



## Wear part replacement

To run the pump for a long period, wear parts need to be replaced periodically. It is recommended that the following parts are always stocked for immediate replacement. Contact us or your nearest distributor for detail.

### Precautions

- Solution in the discharge line may be under pressure. Release the pressure from the discharge line before disconnecting plumbing or disassembly of the pump to avoid solution spray.
- Rinse wet ends thoroughly with tap water.

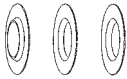
### Wear part list

	Lip seal	Back seat	Disc spring
Part names			
Estimated life	2000hr	Replacement with the lip seal	Replacement with the lip seal
# of parts	3	1	1

\*Wear part duration varies with the pressure, temperature and characteristics of liquid.

\*The estimated life is calculated based on the continuous operation with clean water at ambient temperature.

## Before service is performed

- 1 Turn off power and stop the pump.
- 2 Close the suction line.
- 3 Drain and empty the pump head unit and the discharge line.

## Pump head

See this exploded view when dismantling/assembling the pump. Do not dismantle the pump beyond the extent of instructions in this manual.

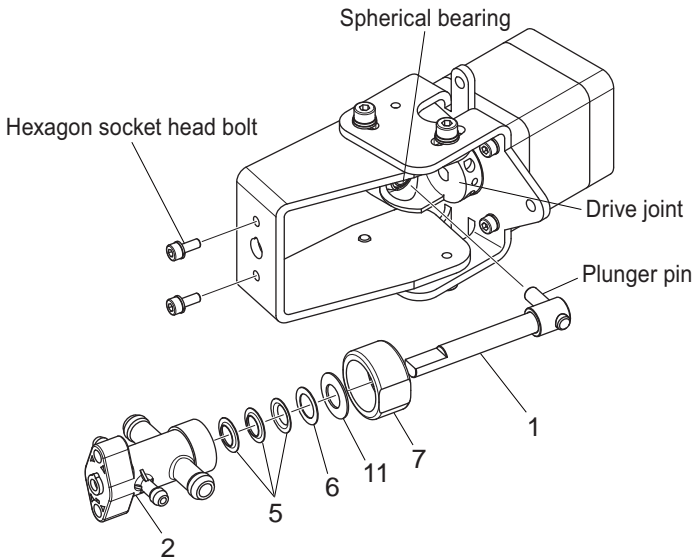

No.	Part names	Q'ty	Materials
1	Plunger	1	Al <sub>2</sub> O <sub>3</sub>
2	Pump head unit	1	PVDF, Al <sub>2</sub> O <sub>3</sub>
5	Lip seal	3	PTFE
6	Back seat	1	PTFE
7	Cap nut	1	GFRPPS
11	Disc spring	1	Stainless steel (fluorine coating)

## ■ Disassembly

### 1 Remove tube connections from the pump head unit (2).

#### NOTE

- Solution in the discharge line may be under pressure. Release the pressure from the discharge line before disconnecting plumbing or disassembly of the pump to avoid solution spray.
- Be careful not to be scratched by outer parts or burrs on them.

### 2 Remove the pump from a foundation.

### 3 Loosen the connection at the top of the pump head unit (2) by removing the hexagon socket head bolts.

### 4 Take out the pump head unit (2) from the spherical bearing with the plunger (1) in it.

### 5 Remove the cap nut (7) from the pump head unit (2) and pull out the plunger (1) by rotating it slowly.

### 6 Slip the lip seals (5) out of the plunger (1) with slow rotation.

#### NOTE

- Be careful not to damage lip seals.
- Clean all parts thoroughly after disassembly.

### 7 Remove the back seat (6), disc spring (11) and cap nut (7) from the plunger (1).

## ■ Assembly

**1 First slide the cap nut (7), disc spring (11), back seat (6) and then lip seals (5) onto the plunger (1) as far as they will go.**

- Take lip seals one by one to softly rotate and slide onto the plunger.
- See the right enlarged photo for the mounting direction of the lip seals.
- Use a 7mm hole expander to widen the I.D. of new lip seals. Leave the seals in the right conditions for 1 hours or more.

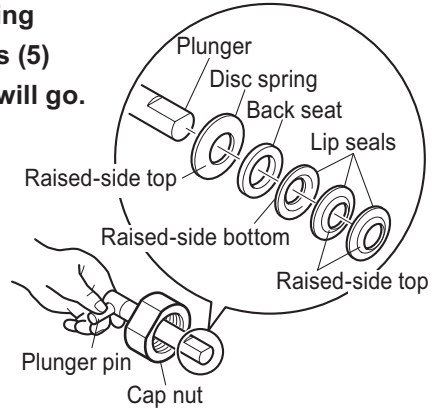

### NOTE

- The disc seal and each lip seal have different mounting directions.
- Do not bend or scratch the lip seals.
- Degrease and clean the plunger with benzine or thinner after this process.

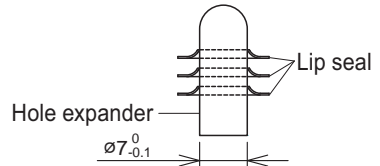

**2 Hold the plunger pin and pass the plunger (1) through the pump head unit (2), rotating it right and left.**

### NOTE

Do not pass the plunger in friction with the pump head unit. Or it may be stuck.

**3 Tighten the cap nut (7) to the pump head unit to 1.5N•m.**

**4 Pull out the plunger end from the pump head unit and apply lubricant.** Use the BALBIS POWER GREEN PG-4000 on the exposed area on the plunger and reciprocate the plunger in the unit about 10 times to make sure good lubrication is kept between them.



## 5 Fit the plunger pin into the spherical bearing.

Use the Dow Corning Toray MOLYKOTE® HP-500 to keep good lubrication in between the plunger pin and the bearing.

## 6 Place the pump head into the pump frame.

Fix the pump head unit at its top by tightening the hexagon socket head bolts to 0.6N•m.

## Specifications/Outer dimensions

### Specifications

Information in this section is subject to change without notice.

#### ■ Pump unit

Model code	Flow volume per shot (mL/shot)	Flow rate (mL/min)	Discharge pressure (kPa)	Stroke rate (rpm)	Weight (kg)
V-07AFP06-P01	0.1	0.5-30	200	5-300	0.7
V-07AFP06-P02	0.2	1-60			

\*The above information is based on pumping clean water at rated voltage and ambient temperature.

\*The flow volume per shot were collected at 100rpm with a discharge line open to the atmosphere.

\*Allowable room temperature: 0-50°C

\*Allowable liquid temperature: 10-40°C

\*Allowable ambient humidity: 35-85%RH

\*The maximum allowable suction lift is 1m, but then can change with liquid characteristics.

\*Flush out the pump head after operation with the crystallizing or adhesive liquid.

#### ■ Stepping motor

Type	Basic step angle	Power voltage	Insulation class
2-phase bipolar	1.8°	24VDC±10%	B

#### ■ Hole IC

Power voltage	Output open-circuit voltage	Output inflow current	Output saturation voltage	Power current
4.5-18DC Vcc	18Vcc	15mA	0.4(Vcc12, I=10mA)	8(Vcc=12V) mA

# Outer dimensions

Sizes are shown in mm.

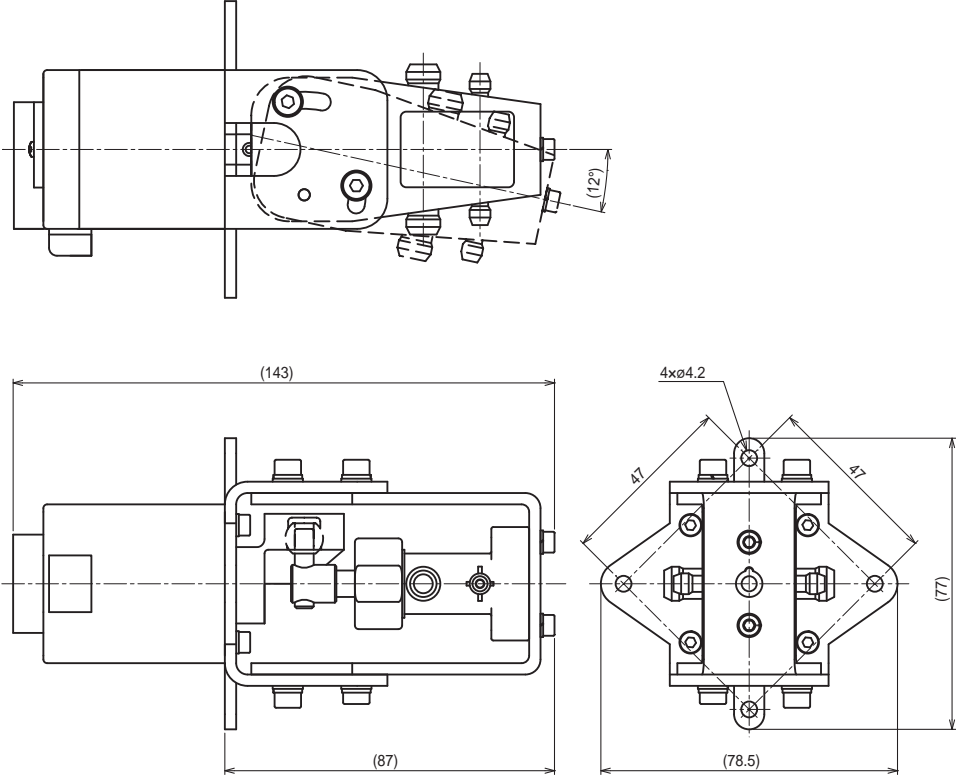

# EC DECLARATION OF CONFORMITY

A copy of the original Declaration of Conformity

(SUPPLIER'S NAME)

WE

IWAKI CO.,LTD.

(ADDRESS)

6-6 2-CHOME KANDA-SUDACHO CHIYODA-KU TOKYO JAPAN

(PRODUCT)

DECLARE UNDER OUR SOLE RESPONSIBILITY THAT THE PRODUCTS  
HICERA PUMP

(MODEL NAME)

V SERIES

TO WHICH THIS DECLARATION RELATES ARE IN CONFORMITY  
WITH THE FOLLOWING STANDARDS OR DIRECTIVES AS FAR AS APPLICABLE

(DIRECTIVES)

MACHINERY DIRECTIVE 2006/42/EC (ANNEX IIA)  
RoHS DIRECTIVE 2011/65/EU

(STANDARDS)

EN ISO12100:2010 EN809:1998+A1:2009 EN IEC63000:2018

(A PERSON WHO IS AUTHORISED TO COMPILE THE TECHNICAL FILE  
IN THE COMMUNITY)

IWAKI EUROPE GMBH  
SIEMENSRING 115 D-47877 WILLICH GERMANY

NOTE: THIS DECLARATION BECOMES INVALID IF TECHNICAL OR OPERATIONAL  
MODIFICATIONS ARE INTRODUCED WITHOUT THE MANUFACTURER'S  
CONSENT.



TSUTOMU SAWADA

DEPUTY SENIOR GENERAL MANAGER,

QUALITY ASSURANCE HEAD OFFICE

Tokyo, Sep. 13, 2021

(PLACE AND DATE OF ISSUE)

(NAME AND SIGNATURE OR EQUIVALENT MARKING OF AUTHORIZED PERSON)

DOCUMENT NO. IS-51K-522-3

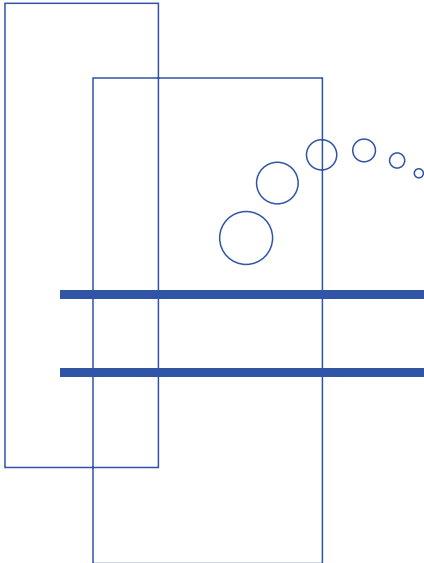

<https://www.iwakipumps.jp>

IWAKI CO.,LTD. 6-6 Kanda-Sudacho 2-chome Chiyoda-ku Tokyo 101-8558 Japan  
TEL: +81 3 3254 2935 FAX: +81 3 3252 8892

**European office** / IWAKI Europe GmbH  
TEL: +49 2154 9254 0 FAX: +49 2154 9254 48

**Germany** / IWAKI Europe GmbH  
TEL: +49 2154 9254 50 FAX: +49 2154 9254 55

**Holland** / IWAKI Europe GmbH (Netherlands Branch)  
TEL: +31 74 2420011 FAX: +49 2154 9254 48

**Italy** / IWAKI Europe GmbH (Italy Branch)  
TEL: +39 0444 371115 FAX: +39 0444 335350

**Spain** / IWAKI Europe GmbH (Spain Branch)  
TEL/FAX: +34 934 741 638

**Poland** / IWAKI Europe Branch EAST  
TEL: +48 12 347 0755 FAX: +48 12 347 0900

**Belgium** / IWAKI Belgium N.V.  
TEL: +32 13 670200 FAX: +32 13 672030

**Denmark** / IWAKI Nordic A/S  
TEL: +45 48 242345

**Finland** / IWAKI Suomi Oy  
TEL: +358 10 201 0490

**France** / IWAKI France S.A.  
TEL: +33 1 69 63 33 70 FAX: +33 1 64 49 92 73

**Norway** / IWAKI Norge AS  
TEL: +47 23 38 49 00

**Sweden** / IWAKI Sverige AB  
TEL: +46 8 511 72900

**U.S.A.** / IWAKI America Inc.  
TEL: +1 508 429 1440 FAX: +1 508 429 1386

**Argentina** / IWAKI America Inc. (Argentina Branch)  
TEL: +54 11 4745 4116

**Brazil** / IWAKI Do Brasil Comercio De Bombas Hidraulicas LTDA.  
TEL/FAX: +55 19 3244 5900

**Singapore** / IWAKI Singapore Pte Ltd.  
TEL: +65 6316 2028 FAX: +65 6316 3221

**Indonesia** / IWAKI Singapore (Indonesia Office)  
TEL: +62 21 6906606 FAX: +62 21 6906612

**Malaysia** / IWAKIm SDN. BHD.  
TEL: +60 3 7803 8807 FAX: +60 3 7803 4800

**Australia** / IWAKI Pumps Australia Pty Ltd.  
TEL: +61 2 9899 2411 FAX: +61 2 9899 2421

**China** (Hong Kong) / IWAKI Pumps Co., Ltd.  
TEL: +852 2607 1168 FAX: +852 2607 1000

**China** (Guangzhou) / GFTZ IWAKI Engineering & Trading Co., Ltd.  
TEL: +86 20 84350603 FAX: +86 20 84359181

**China** / IWAKI Pumps (Shanghai) Co., Ltd.  
TEL: +86 21 6272 7502 FAX: +86 21 6272 6929

**Korea** / IWAKI Korea Co., Ltd.  
TEL: +82 2 2630 4800 FAX: +82 2 2630 4801

**Taiwan** / IWAKI Pumps Taiwan Co., Ltd.  
TEL: +886 2 8227 6900 FAX: +886 2 8227 6818

**Thailand** / IWAKI (Thailand) Co., Ltd.  
TEL: +66 2 322 2471 FAX: +66 2 322 2477