

# **IWAKI Air Servo Unit**

---

## **For the AX series pump**

---

### **Instruction Manual**

---

 Read this manual before use of product

Thank you for selecting an Iwaki AX metering pump with an air servo unit. This instruction manual deals with “*Safety instructions*”, “*Outline*”, “*Installation*”, “*Operation*” and “*Maintenance*” sections. Please read through this manual carefully to ensure the optimum performance, safety and service of your pump.

## Contents

<b>Important instructions</b> .....	<b>1</b>
<b>Safety instructions</b> .....	<b>2</b>
<i>Outline</i>	
1. Unpacking & Inspection .....	5
2. Operating principle .....	5
3. Specification .....	6
<i>Installation</i>	
1. Before installation.....	7
2. Piping & Wiring.....	7
<i>Operation</i>	
1. Operation.....	9
2. Adjustments.....	11
<i>Maintenance</i>	
1. Troubleshooting .....	14
2. Maintenance & Inspection .....	15



*This instruction manual should be kept on hand by the end user for quick reference.*

*Contact us or your nearest dealer if you have any questions.*

# Important instructions

## For the Safe and Correct Handling of the Pump

- “Safety Instruction” section deals with important details about handling of the product. Before use, read this section carefully for the prevention of personal injury or property damage.
- Observe the instructions accompanied with “WARNING” or “CAUTION” in this manual. These instructions are very important for protecting users from dangerous situations.
- The symbols on this instruction manual have the following meanings:

 <b>WARNING</b>	<b>Nonobservance or misapplication of “Warning” sections could lead to a serious accident which may result in death.</b>
 <b>CAUTION</b>	<b>Nonobservance or misapplication of “Caution” sections could lead to personal injury or property damage.</b>

### Types of Symbols



Indicates that “Warning” or “Caution” must be exercised. Inside this triangle, a concrete and practical image provided as a warning or caution message is depicted.



Indicates a prohibited action or procedure. Inside or near this circle, a concrete and practical image of the activity to be avoided is depicted.



Indicates an important action or procedure which must be performed or carried out without fail. Failure to follow the instructions herein can lead to malfunction or damage to the pump.

### **Export Restrictions**

Technical information contained in this instruction manual might be treated as controlled technology in your countries, due to agreements in international regime for export control. Please be reminded that export license/permission could be required when this manual is provided, due to export control regulations of your country.

# Safety instructions

## **WARNING**

- **Turn off power before service**

Risk of electrical shock. Be sure to turn off power to stop the pump and related devices before service is performed.



Turning off power

- **Wear protective clothing**

Always wear protective clothing such as an eye protection, chemical resistant gloves, a mask and a face shield during disassembly, assembly or maintenance work.



Wear protective gear

- **When checking & replacing the enclosed liquid (double diaphragm type)**

Be sure to turn off power before rotating the motor fan manually.



Caution

- **Use strong ropes (chains) for lifting up the pump**

Keep away from the pump while it is lifted up for installation. Serious injury may result if lifting ropes (chains) break. Check lifting ropes (chains) are strong enough before use. Observe the maximum weight of the rope (chains).



Requirement

- **Use eye bolts**

Chain the pump via eye bolts to lift it up. Otherwise the pump may accidentally fall down, resulting in serious injury.



Requirement

- **Stay out from under suspended loads**

Risk of personal injury. Keep away from the pump while it is lifted up.



Prohibited

- **Qualified personnel only**

This product should be handled or operated by qualified personnel with a full understanding. Any person not familiar with the product should not take part in the operation or maintenance of the pump.



Caution

- **Do not modify the product**

Alterations to the product carries a high degree of risk. It is not the manufacturer's responsibility for any failure or injury resulting from alterations to the pump.



No Remodeling

- **Do not use the pump in any condition other than its intended purpose**

The use of the pump in any conditions other than those clearly specified may result in failure or injury. Use this product in specified conditions only.



Prohibited

- **Do not stand on the pump**

Do not use the pump as a platform. Injury or damage may result when the pump turns over.



Prohibited

- **Do not get access to the inside of the drive unit during operation**

Risk of personal injury. A reciprocating diaphragm/shaft may catch the finger or hand.



Caution

# Safety instructions

## CAUTION

### • Ventilation

Fumes or vapours can be hazardous with certain solutions. Ensure proper ventilation at the operation site.



### • Do not bring the pump close to a flammable substance

Keep the pump away from a flammable substance for the prevention of fire.



### • Do not touch the pump or pipe with bare hands

Risk of burning. The surface temperature of the pump or pipe rises high along with liquid temperature in or right after operation.



### • Be sure to turn off all the related power supplies prior to any inspection/ maintenance and installation works (motor fan cover).

Working on the pump with power ON, any rotating part may catch the hand, finger, hair, or clothes, and it may result in serious injury.



### • Do not remove the Coupling cover

Never remove the Coupling cover during operation. Touching the shaft when it is rotating, serious injury may result.



### • Do not use a damaged pump

Use of a damaged pump could lead to an electric shock or death.



### • Grounding

Risk of electrical shock! Always properly ground the pump. Conform to local electric codes.



### • Use specified power only

Do not apply power other than that specified on the nameplate. Otherwise, failure or fire may result. Ensure the pump is properly grounded.



### • Install an earth leakage breaker

An electrical failure of the pump may adversely affect other devices on the same line. Purchase and install an earth leakage breaker separately.



### • Do not install/store the pump:

- In a flammable/explosive/corrosive atmosphere.
- In a dusty/humid environment.
- Where ambient temperature can exceed 0-40°C.
- In direct sunlight or wind & rain (except outdoor-use models).



# Safety instructions

## CAUTION

- **Closed-discharge operation is not allowed**

Do not close a discharge line during operation. Otherwise, overpressure will cause liquid leakage or break the pump and piping.



- **Keep away from around the pump when turning ON power**

The pump doesn't have an ON-OFF switch and starts as the rated power is supplied.



- **Do not cover the pump with cloth**

The motor temperature may build up and a fire or an electric/mechanical failure may result.



- **Before leaving the pump for a long period**

Remove a chemical liquid and clean the pump.



- **Non-freezing**

Frozen liquid may damage the pump and piping. Drain liquid before leaving it for a long time or use measures to prevent liquid from freezing in winter.



- **Do not close a suction or a discharge valve in operation**

Closed-suction or closed-discharge operation damages the pump, piping, or motor.



- **Do not touch the control knob or the slide shaft in operation**



- **Spill precautions**

Ensure protection and containment of solution in the event of plumbing or pump damage (secondary containment).



- **Debris**

When debris enter the pump, turn off power at once and remove them. Use of the pump with debris in it may result in failure.



- **Disposal of the product**

Dispose of any used or damaged product in accordance with local rules and regulations. If necessary, consult a licensed industrial waste disposal company.



- **Keep the spec label and nameplate clean**

If labels and a nameplate has become unglued or illegible, contact us to replace them with new ones.



# Outline

## 1. Unpacking & Inspection

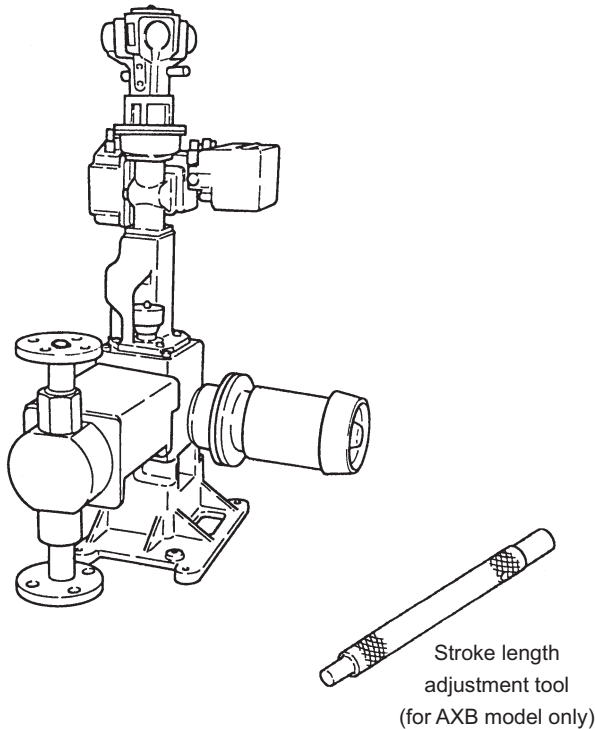

Please check the following before using the product.

- 1 Check the delivery is correct.  
Check the model, capacity, delivery pressure, voltage, etc., specified on the nameplate are correct.
- 2 Check if all the accessories are included. (for AXB model only)  
Stroke length adjustment tool : 1pcs
- 3 Check if the delivery was damaged or deformed during the transport.  
Check visually or using fingers if the delivery was damaged and/or the bolts were loosened due to accident(s) during the transport.

note) If any defect, problem or inconsistency is found, contact your distributor.

## 2. Operating principle

The feedback mechanism of the air servo unit is the force equilibrium mechanism. The positioner compares the force generated by input signals sent from the signal source such as a controller or remote operation unit with the tensile force on the feedback spring (actual pump stroke length) and rotates the air motor in either forward or reverse direction based on the deviation. Rotations of the air motor are transmitted to the stroke length adjustment mechanism via the gear box (including geared) to

change the pump stroke length. The pump stroke length (amount of rotation of the stroke adjustment dial) is fed back to the positioner via the gear. When the tensile force on the feedback spring of the positioner and the force generated by input signals reach a state of equilibrium, the air motor stops, and pump stroke length setup is complete. The mechanical valve is installed to protect the pump mechanism and servo unit in case that input signals other than those specified are accidentally input.

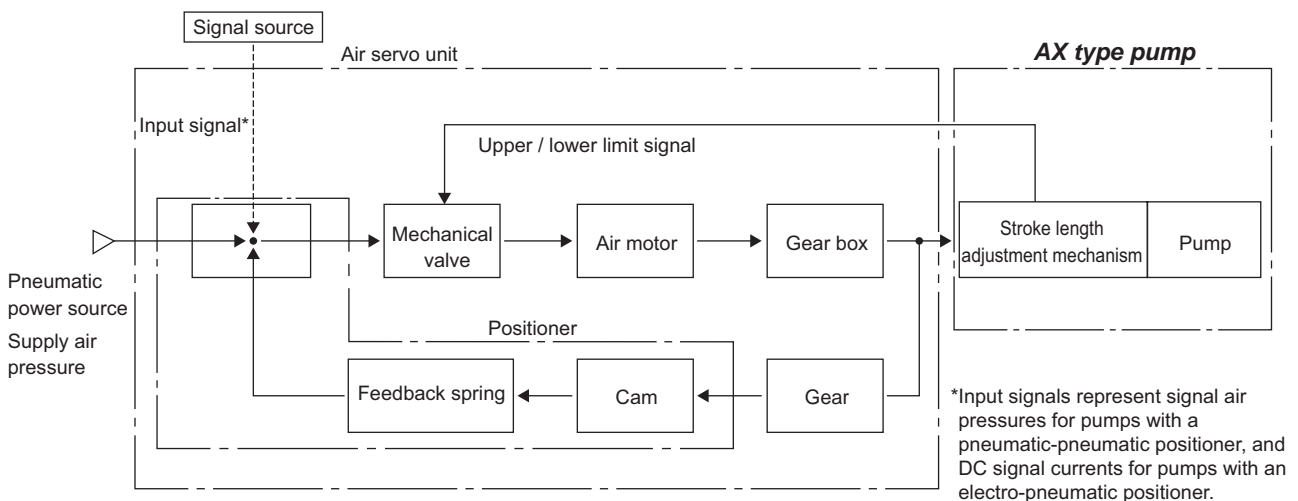

# Outline

## 3. Specification

Specifications		Pump model	
		AXJ, AXK, AXA	AXB
Supply air pressure (SUP)	Standard	0.3MPa [3kgf/cm <sup>2</sup> ]	
	Maximum	0.6MPa [6kgf/cm <sup>2</sup> ]	
Input signal (SIG)	(With a pneumatic-pneumatic positioner) air pressure	0.0196 to 0.0981MPa [0.2 to 1.0kgf/cm <sup>2</sup> ]	
	(With an electro-pneumatic positioner), mA direct current (DC)	4 to 20	Input resistance 235Ω Flameproof enclosure d <sub>2</sub> G4
Air consumption amount, NL/min Normal air consumption amount Maximum air consumption amount		(SUP0.3MPa [3kgf/cm <sup>2</sup> ])	
		Less than 30	
		Less than 100	
Servo operation time [sec] * <sup>1</sup>		20	25
Operating ambient temperature [°C]		5 to 40	
Adjustment accuracy [%] * <sup>2</sup>		Pneumatic-pneumatic positioner: ±3%F.S (Electro-pneumatic positioner: ±2.5%F.S) * <sup>3</sup>	

\*1 The operation time varies to a certain extent, depending on the pump load.

\*2 The adjustment accuracy represents the accuracy during pump operation.

\*3 F.S represents the 100% pump stroke length.



# Installation

## 1. Before installation

- 1 Install the air set within 1m from the air servo unit from a perspective of operation and pressure loss.
- 2 Before performing pipework, remove any foreign material such as rust and burr completely.
- 3 Apply a small amount of liquid pipe seal to the screw connected parts before connecting. Do not use sealing tape as its crumbs may get stuck in the air servo unit.
- 4 Use dehumidified and dedusted clean instrument air for air to be supplied to the air servo unit (SUP, SIG).

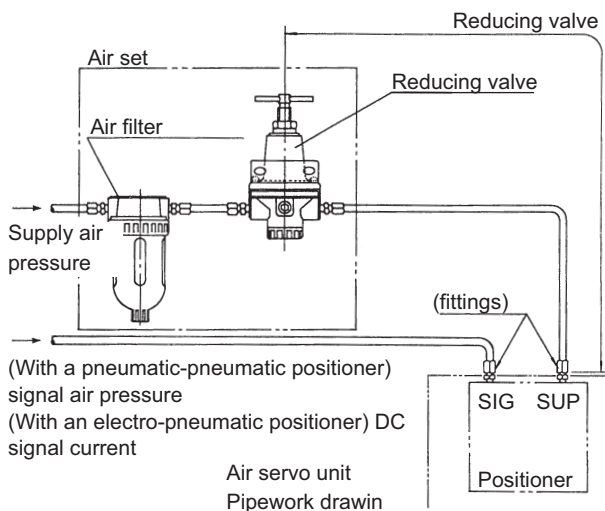

## 2. Piping & Wiring

### [With a pneumatic-pneumatic positioner]

Connect the pipes for supply air (SPU) and input signals (SIG) to the respective fittings for the air set, supply air pressure and signal air pressure.

- 1 For pipes, use mild steel pipes or nylon tubes which are 6mm OD and 4mm ID. Also, cut the pipes at the right angle.



- 2 Insert the cut pipes until they are in direct contact with the flaring edge, and then tighten the nuts by hands.
- 3 Tighten the nuts further using a tightening tool. For mild steel pipes, rotate the nuts one time. For

nylon tubes, rotate the nuts one and a half times.

- 4 Space between the properly tightened nuts and the axial direction of the body is roughly 2mm.

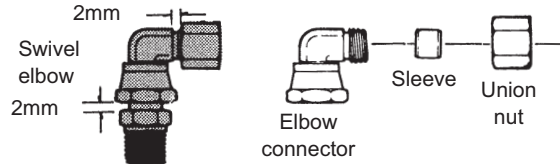

### [With an electro-pneumatic positioner]

Follow the procedure below to connect the pipes for supply air (SPU) and input signals (SIG).

- 1 Connect the pipes for supply air (SUP) to the respective fittings of the air set and supply air pressure. For the instructions of piping, refer to the "With a pneumatic-pneumatic positioner" section.
- 2 Follow the procedure below to perform wiring for signal sources such as a controller and servo unit.
  1. Remove the terminal cover. (The specialized tool is included.)

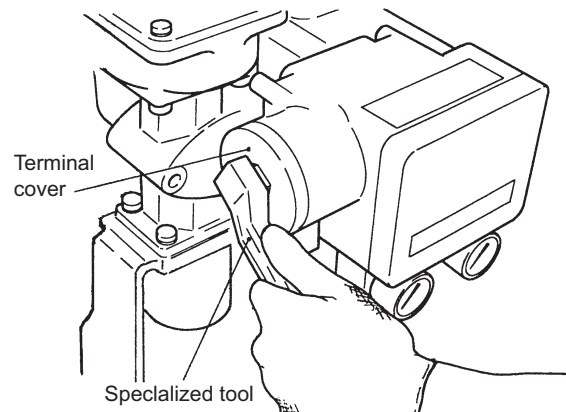

2. Connect the output terminals from signal sources such as a controller to the corresponding input terminals of the positioner. When connecting, pay close attention to the polarity (+/-) of the terminals. The diameter of the conducting wire entrance is a parallel pipe thread G 1/2, 20mm deep.

# Installation

---

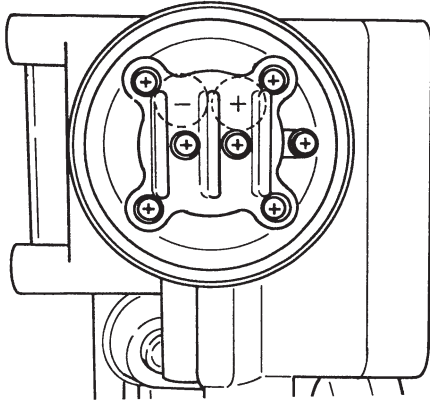

3. Follow the procedure below to perform wiring when using an electro-pneumatic positioner as a flameproof enclosure (d<sub>2</sub>G4).  
For electrical conduit pipes, use thick steel electrical conduit pipes (JIS C 8305) and bind the screws completely by using lock nuts for thick steel electrical conduit pipes (JIS C 8333).  
For electrical wires, use insulated wires.

# Operation

## 1. Operation

### ■ Checking the operation condition

The pump and servo unit are adjusted prior to shipping. But still, follow the procedure below to check their operating conditions before putting them into full operation.

#### ● Manual operation

1. Rotate the slide shaft attached to the control knob of the pump using a spanner (width across 35mm flats) or a stroke length adjustment tool (For AXB models, the specialized tool is included.), and then adjust the stroke length to the specified level. Additionally, be sure to turn off supply air before adjusting the stroke length manually.

#### ⚠ Caution

When adjusting the stroke length manually, be sure not to exceed the limit switch adjustment range (Pump stroke lengths, 0% and 100%, are set as the limit function.).

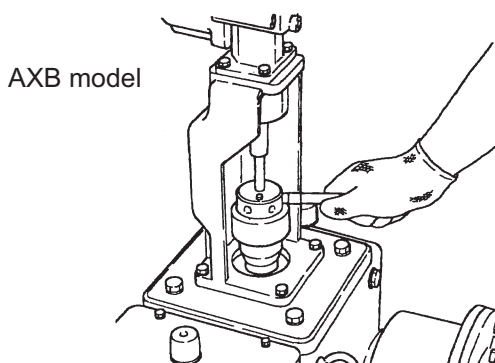
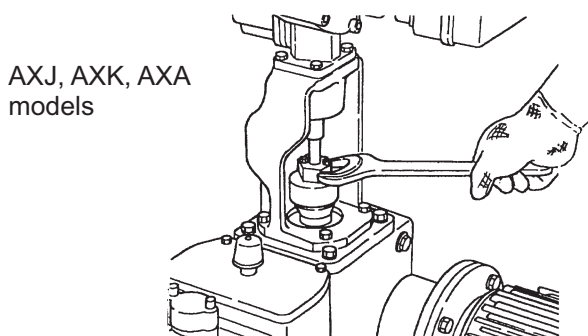

2. Follow the "Operation" section in the instruction manual for AX models to operate the pump and check if the pump feeds liquid properly.

#### Automatic operation

Be sure to operate the pump while operating the servo unit.

### [With a pneumatic-pneumatic positioner]

1. Supply air to the air set.
2. Adjust the adjustment screw on the reducing valve so that the supply air pressure is set to the specified pressure of 0.3MPa [3kgf/cm<sup>2</sup>].
3. Set the signal pressure to 0.0196MPa [0.2kgf/cm<sup>2</sup>]. Under this condition, check that the pump stroke length is set to 0% using a stroke length scale. If the pump stroke length deviates from 0% at this point, make zero point adjustment. (For more information, refer to the "Zero point adjustment" section.)
4. Set the signal pressure to 0.0981MPa [1kgf/cm<sup>2</sup>]. Under this condition, check that the pump stroke length is set to 100%. If the pump stroke length deviates from 100% at this point, make span adjustment. (For more information, refer to the "Span adjustment" section.)
5. Once the zero point and span have been checked, follow the procedure below to check the adjustment accuracy.
  - Raise the signal pressure in 0.0196MPa [0.2kgf/cm<sup>2</sup>] increments from 0.0196MPa [0.2kgf/cm<sup>2</sup>] to 0.0981MPa [1kgf/cm<sup>2</sup>], and then lower it down to 0.0196MPa [0.2kgf/cm<sup>2</sup>]. At this point, read the stroke length relative to each signal pressure, and then check the adjustment accuracy.

### [With an electro-pneumatic positioner]

1. Supply air to the air set.
2. Adjust the adjustment screw on the reducing valve so that the supply air pressure is set to the specified pressure of 0.3MPa [3kgf/cm<sup>2</sup>].
3. Set the signal current to 4mA. Under this condition, check that the pump stroke length is set to 0% using a stroke length scale. If the pump stroke length deviates from 0% at this point, make span adjustment. (For more information, refer to the "Span adjustment" section.)

# Operation

4. Then, set the signal current to 20mA. Under this condition, check that the pump stroke length is set to 100%. If the pump stroke length deviates from 100% at this point, make span adjustment. (For more information, refer to the "Span adjustment" section.)
5. Once the zero point and span have been checked, follow the procedure below to check the adjustment accuracy.
  - Raise the signal current in 4mA increments from 4mA to 20mA, and then lower it down to 4mA. At this point, read the stroke length relative to each signal current, and then check the adjustment accuracy.

## ■ How to operate the pump

- 1 Once the adjustment accuracy has been checked, check that the supply air pressure is set to the specified valve again.
- 2 Supply the signal pressure (current) to the servo unit, and then follow the pump instruction manual to operate the pump.

## ■ Relationship between input signals and operation

To control pump capacity, the relationship between capacity and input signals is important. The pump test result table indicates the relationship between the pump capacity and stroke length. However, this test result table represents the test results conducted by using clean water instead of actual pipes and real liquid. Therefore, to accurately control pump capacity, it is recommended that the relationship between the stroke length and capacity be presented in a graph under the actual usage conditions. (Refer to the pump instruction manual.)

The relationship between the stroke length and input signals (for a pneumatic-pneumatic positioner, signal pressures instead of input signals; for an electro-pneumatic positioner, signal currents instead of input signals) for the air servo unit is shown in the illustration on the right.

### <With a pneumatic-pneumatic positioner>

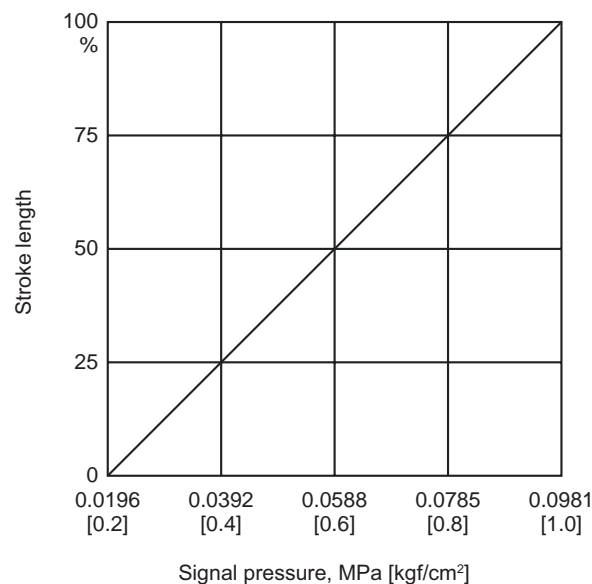

### <With an electro-pneumatic positioner>

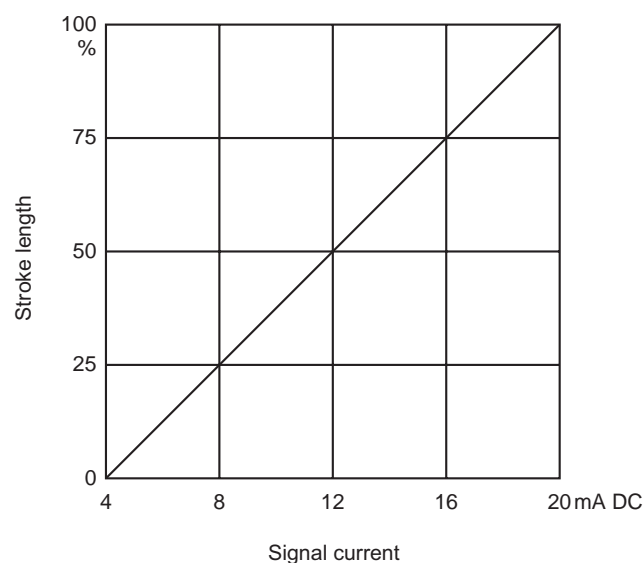

# Operation

## 2. Adjustments

### ■ Instructions about adjustment

- 1 Make adjustment while operating the pump.
- 2 When making zero point and span adjustment, either of the zero point or span deviates from the adjusted level, if only either of them is adjusted. Repeat both adjustments alternately until they are adjusted properly.
- 3 If both are adjusted, check the adjustment accuracy. Note that the accuracy becomes lower than the specifications if the sensitivity is lowered by sensitivity adjustment. (Refer to the Automatic operation section.)
- 4 If the pump is equipped with an electro-pneumatic positioner and the terminal cover needs to be removed for adjustment, be sure to turn off the input signal before making adjustment. Especially when the pump is installed in a location where there is a risk of fire, much caution is required.
- 5 When installing the pump and performing its pipework and wiring, its properties may be deteriorated if shock is applied to the torque motor chamber or a great force is applied to the movable single arm of the electro-pneumatic positioner and feedback lever section of the pneumatic-pneumatic positioner. Much caution is required.

### [With a pneumatic-pneumatic positioner]

#### ■ Span adjustment

Span adjustment means adjusting the pump stroke length to 100% relative to the reference signal (signal pressure), 0.0981MPa [1kgf/cm<sup>2</sup>].

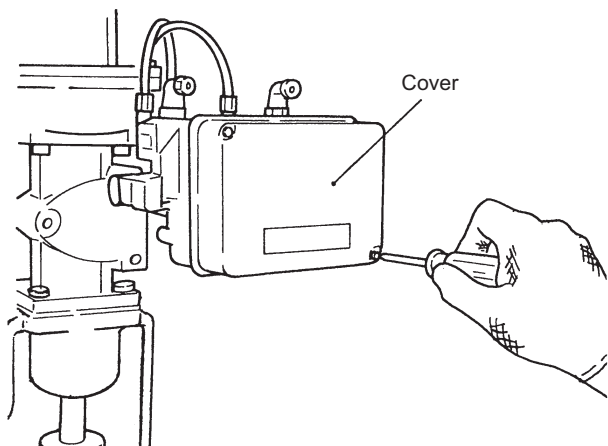

- 1 Use a screwdriver to remove the cover.
- 2 Set the input signal to 0.0275MPa [0.28kgf/cm<sup>2</sup>] (10%), and then read the pump stroke length. (The pump stroke length at this point is expressed by A%.)
- 3 Set the input signal to 0.0902MPa [0.92kgf/cm<sup>2</sup>] (90%), and then read the pump stroke length. (The pump stroke length at this point is expressed by B%.)
- 4 Rotate the span adjustment roller so that the value of B%-A% is set to 80% (the value of 90%-10%=80%). If the value of B%-A% is greater than 80%, rotate the span adjustment roller counterclockwise to make span smaller. If the value of B%-A% is smaller than 80%, rotate the span adjustment roller clockwise to make span greater. The standard effective number of coils for the feedback spring is approximately 4.

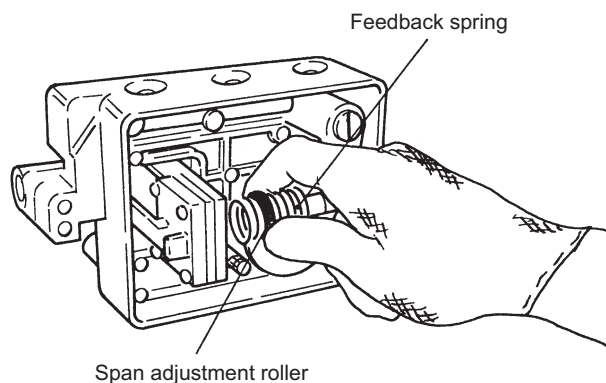

- 5 Repeat steps 2 through 4 until the value of B%-A% is set to 80%. Then, span adjustment is complete.

#### ⚠ Caution

When the span adjustment roller is rotated, the position of the zero point shifts. If the 80% span cannot be read when the pump stroke length is in the range of 0% to 100%, make zero point adjustment. (Pump stroke lengths, 0% and 100%, are set as the limit function.)

# Operation

## ■ Zero point adjustment

Zero point adjustment means adjusting the pump stroke length to 0% relative to the reference signal (signal pressure), 0.0196MPa [0.2kgf/cm<sup>2</sup>]. Make zero point adjustment after span adjustment is completed.

- 1 Set the input signal to 0.0275MPa [0.28kgf/cm<sup>2</sup>] (10%), and then tighten the lock nut.

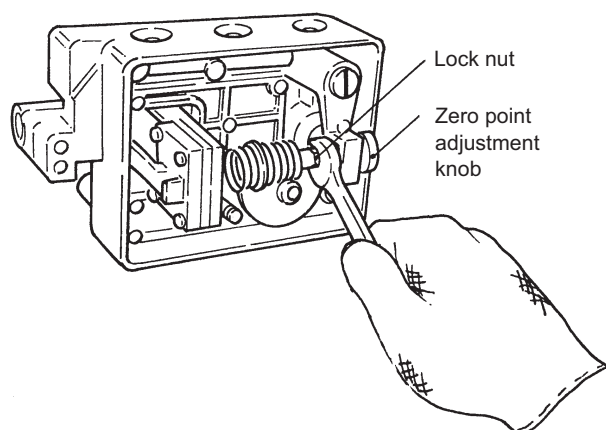

- 2 Rotate the zero point adjustment knob to change the tensioning force of the feedback spring, and then set the pump stroke length to the position of 10%. The pump stroke length decreases by rotating the zero point adjustment knob clockwise and increases by rotating the knob counterclockwise.
- 3 Set the input signal to 0.0196MPa [0.2kgf/cm<sup>2</sup>], and then check that the pump stroke length is set to 0%. If the pump stroke length cannot be set to 0%, rotate the zero point adjustment knob until it is set to the position of 0%.
- 4 Once adjustment has been completed, retighten the lock nut.
- 5 Attach the cover.

## ■ Checking the adjustment accuracy

Raise the signal in 0.0196MPa [0.2kgf/cm<sup>2</sup>] increments from 0.0196MPa [0.2kgf/cm<sup>2</sup>] to 0.0981MPa [1kgf/cm<sup>2</sup>], read the stroke length relative to each input signal, and then check the adjustment accuracy.

## [With an electro-pneumatic positioner]

## ■ Span adjustment

Span adjustment means adjusting the pump stroke length to 100% relative to the reference signal (20mA).

- 1 Use a screwdriver to remove the cover.

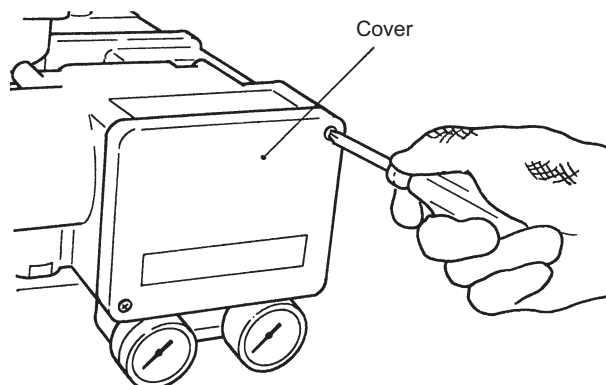

- 2 Set the input signal to 5.6mA (10%), and then read the pump stroke length. (The pump stroke length at this point is expressed by A%.)
- 3 Set the input signal to 18.4mA (90%), and then read the pump stroke length. (The pump stroke length at this point is expressed by B%.)
- 4 Loosen the lock screw.

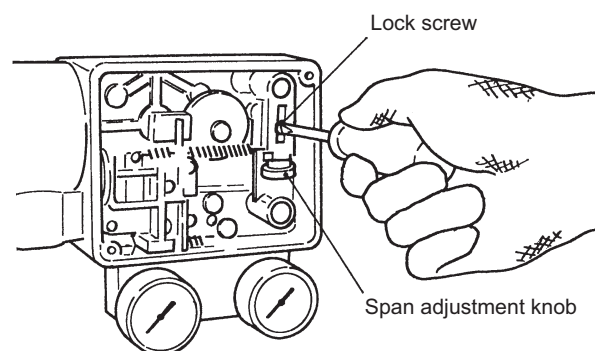

- 5 Rotate the span adjustment knob so that the value of B%-A% is set to 80% (the value of 90%-10%=80%). If the value of B%-A% is greater than 80%, rotate the span adjustment knob counterclockwise to make span smaller. If the value of B%-A% is smaller than 80%, rotate the span adjustment knob clockwise to make span greater. Also, "+SPAN-" is imprinted on the span adjustment lever.



# Operation

- 6 Repeat steps 2 through 5 until the value of B%-A% is set to 80%. Then, span adjustment is complete.

## ⚠ Caution

When the span adjustment knob is rotated, the position of the zero point shifts. If 80% of the span cannot be read when the pump stroke length is in the range of 0% to 100%, make zero point adjustment. (Pump stroke lengths, 0% and 100%, are set for the limit function.)

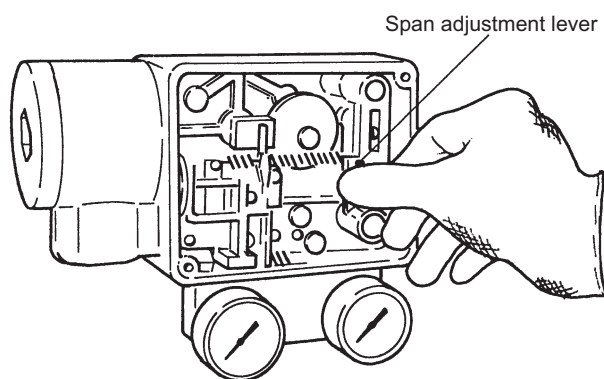

- 7 Once adjustment has been completed, retighten the lock screw.

## ■ Zero point adjustment

Zero point adjustment means adjusting the pump stroke length to 0% relative to the reference signal (signal current of 4mA). Make zero point adjustment after span adjustment is completed.

- 1 Set the input signal to 5.6mA (10%), and then rotate the zero point adjustment knob until it is set to the position of 10%. The pump stroke length decreases by rotating the zero point adjustment knob clockwise and increases by rotating the knob counterclockwise.

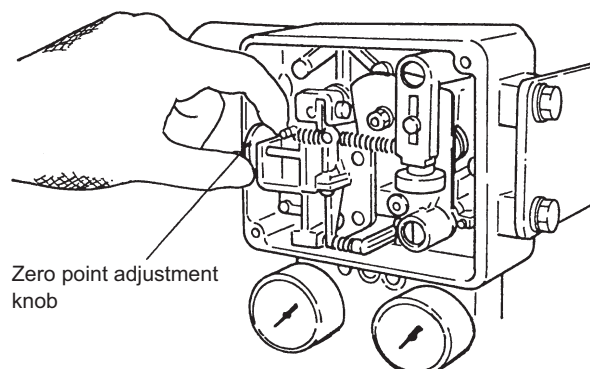

- 2 Set the input signal to 4mA (0%), and then check that the pump stroke length is set to 0%. If the pump stroke length cannot be set to 0%, rotate the zero point adjustment knob until it is set to the position of 0%.

- 3 Attach the cover.

## ■ Checking the adjustment accuracy

Raise the input signal in 4mA increments from 4mA to 20mA, then lower it down to 4mA, read the stroke length relative to each input signal, and then check the adjustment accuracy.

## ■ Sensitivity adjustment

Sensitivity adjustment means adjusting the sensitivity of the positioner (non-sensitivity zone). Lowering the sensitivity prevents hunting of the signal system and positioner itself. The sensitivity is already adjusted by Iwaki Co., Ltd. Do not make sensitivity adjustment during normal operation. (Rotating the adjustment screw counterclockwise lowers the sensitivity.)

## ■ Suppression

The stroke length can be sequentially suppressed to approximately the 60% stroke length by the standard input signal, if necessary.

note) For the instructions on how to make adjustment, refer to the "Span adjustment" section. When making adjustment, regard the 100% stroke length as the stroke length (%) to be suppressed.

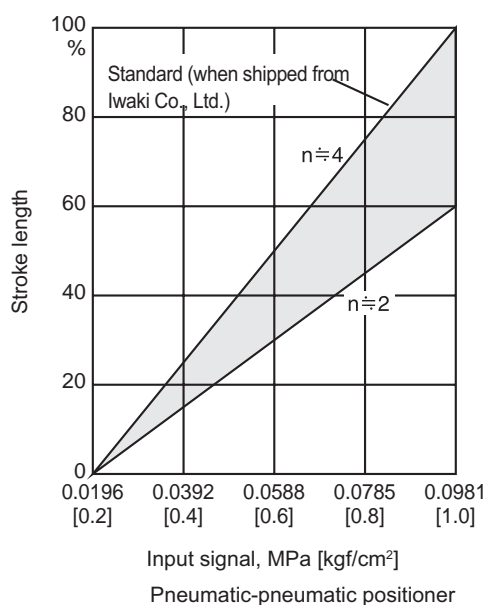

- ▶ The "n" code represents the number of coils for the feedback spring. (Reference for adjustment)
- ▶ The shaded areas represent the adjustment (suppression) range.

# Maintenance

## 1. Troubleshooting

Troubles	Point to be checked	Causes	Measures
<p>The servo unit does not operate.</p> <p>The servo unit operates only in one direction.</p> <p>The servo unit does not operate smoothly.</p>	(the positioner)	<ul style="list-style-type: none"> <li>● The fixed throttle (16) is clogged.</li> <li>● The filter (12) is clogged.</li> <li>● The nuts are loosened.</li> </ul>	<ul style="list-style-type: none"> <li>○ Clean with the cleaning pin (14).</li> <li>○ Clean the filter (12).</li> <li>○ Tighten the nuts.</li> </ul>
	(pipework)	<ul style="list-style-type: none"> <li>● The supply air pressure is lowered.</li> <li>● Input signal not received.</li> </ul>	<ul style="list-style-type: none"> <li>○ Check leakage of the pipes.</li> <li>○ Set the pressure of the reducing valve again.</li> <li>○ Input an input signal.</li> </ul>
	(pump)	<ul style="list-style-type: none"> <li>● There are problems with the pump section.</li> </ul>	<ul style="list-style-type: none"> <li>○ Inspect and reassemble the pump section.</li> </ul>
	(air motor)	<ul style="list-style-type: none"> <li>● Rust is occurring (due to water contained in the air pipeline).</li> <li>● Burnt (due to engagement of debris).</li> </ul>	<ul style="list-style-type: none"> <li>○ Disassemble and clean the air motor (419).</li> <li>○ Disassemble and clean the air motor.</li> </ul>
Hunting occurs.	(the positioner)	<ul style="list-style-type: none"> <li>● The fixed throttle is clogged.</li> </ul>	<ul style="list-style-type: none"> <li>○ Clean with the cleaning pin.</li> </ul>
	(pipework)	<ul style="list-style-type: none"> <li>● Input signals are unstable.</li> </ul>	<ul style="list-style-type: none"> <li>○ Check the signal system.</li> </ul>
Bad sensitivity.	(the positioner)	<ul style="list-style-type: none"> <li>● The adjustment screws (10) are adjusted incorrectly.</li> <li>● The nuts are loosened.</li> </ul>	<ul style="list-style-type: none"> <li>○ Readjust the adjustment screws.</li> <li>○ Tighten the nuts.</li> </ul>
	(pipework)	<ul style="list-style-type: none"> <li>● Delay of input signal or leakage from piping of supply air pressure.</li> </ul>	<ul style="list-style-type: none"> <li>○ Check the pipes.</li> </ul>
Excessive air consumption.	(the positioner)	<ul style="list-style-type: none"> <li>● The shutoff cock is loosened.</li> <li>● Debris is adhered to the valve rods (8) and (11).</li> </ul>	<ul style="list-style-type: none"> <li>○ Check and tighten the shutoff cock.</li> <li>○ Clean the valve rod.</li> </ul>
<p>The specified range of the pump stroke length exceeds or falls short of the range of 0% to 100%.</p>	(servo)	<ul style="list-style-type: none"> <li>● Erroneous set up of the limit cam (456).</li> <li>● The mechanical valve (460) is operating incorrectly.</li> </ul>	<ul style="list-style-type: none"> <li>○ Perform setup again.</li> <li>○ Inspect the pipes and mechanical valve.</li> </ul>
	(the positioner)	<ul style="list-style-type: none"> <li>● The zero point and span are adjusted incorrectly.</li> <li>● The nozzle is clogged.</li> </ul>	<ul style="list-style-type: none"> <li>○ Perform adjustment again.</li> <li>○ Disassemble and clean the positioner.</li> </ul>
	(pipework)	<ul style="list-style-type: none"> <li>● The supply air pressure is lowered.</li> </ul>	<ul style="list-style-type: none"> <li>○ Check the pipes and operation condition of the stop valve.</li> </ul>



# Maintenance

## 2. Maintenance & Inspection

To ensure smooth operation of the air servo unit, perform the following routine inspections at regular intervals.

### ■ Pipework

- 1 Check if no leaks are occurring from the pipes and joints.
- 2 Check if supply air is clean, the air pressure is maintained at the proper level, and the amount of air is secured.
- 3 Drain water from the air filter, clean it, and remove debris adhered to it at regular intervals.

### ■ Positioner

- 1 To resume pump operation after the pump has been stopped for an extended period of time, clean the fixed throttle.
- 2 Clean the fixed throttle once every one to three months.

### ■ How to clean the fixed throttle

Push the cleaning pin two or three times using a finger, with supply air pressure applied. Note that the pump stroke length changes if the cleaning pin is pressed during control.

<With a pneumatic-pneumatic positioner>

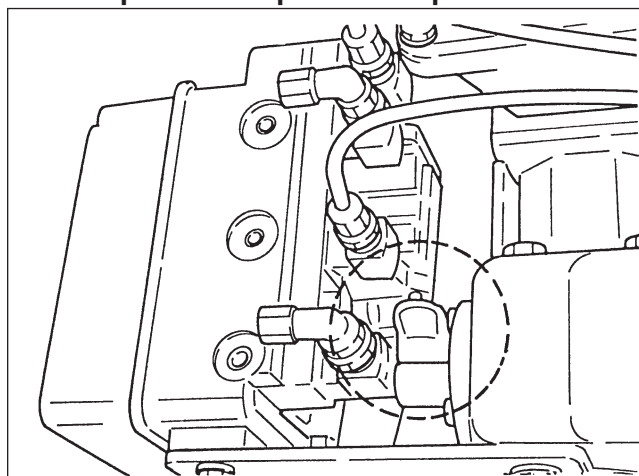

<With an electro-pneumatic positioner>

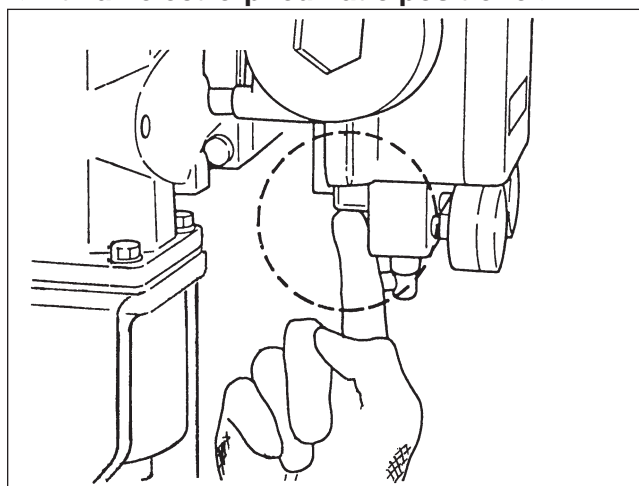

### ■ Special accessories (options)

Name	Model
Air filter	AF30-03B-A
Reducing valve	AR30-03BG-B
Manually-operated remote control unit	ML15-111
	ML15-211 <Equipped with AUTO / MANUAL switching valve>

If you purchase our special accessories, they are separately packaged for transport reasons. (except for the positioner)

# Maintenance

## ■ Servo unit section

- Structural drawing of the pneumatic-pneumatic servo unit

<AXJ, K, A models>

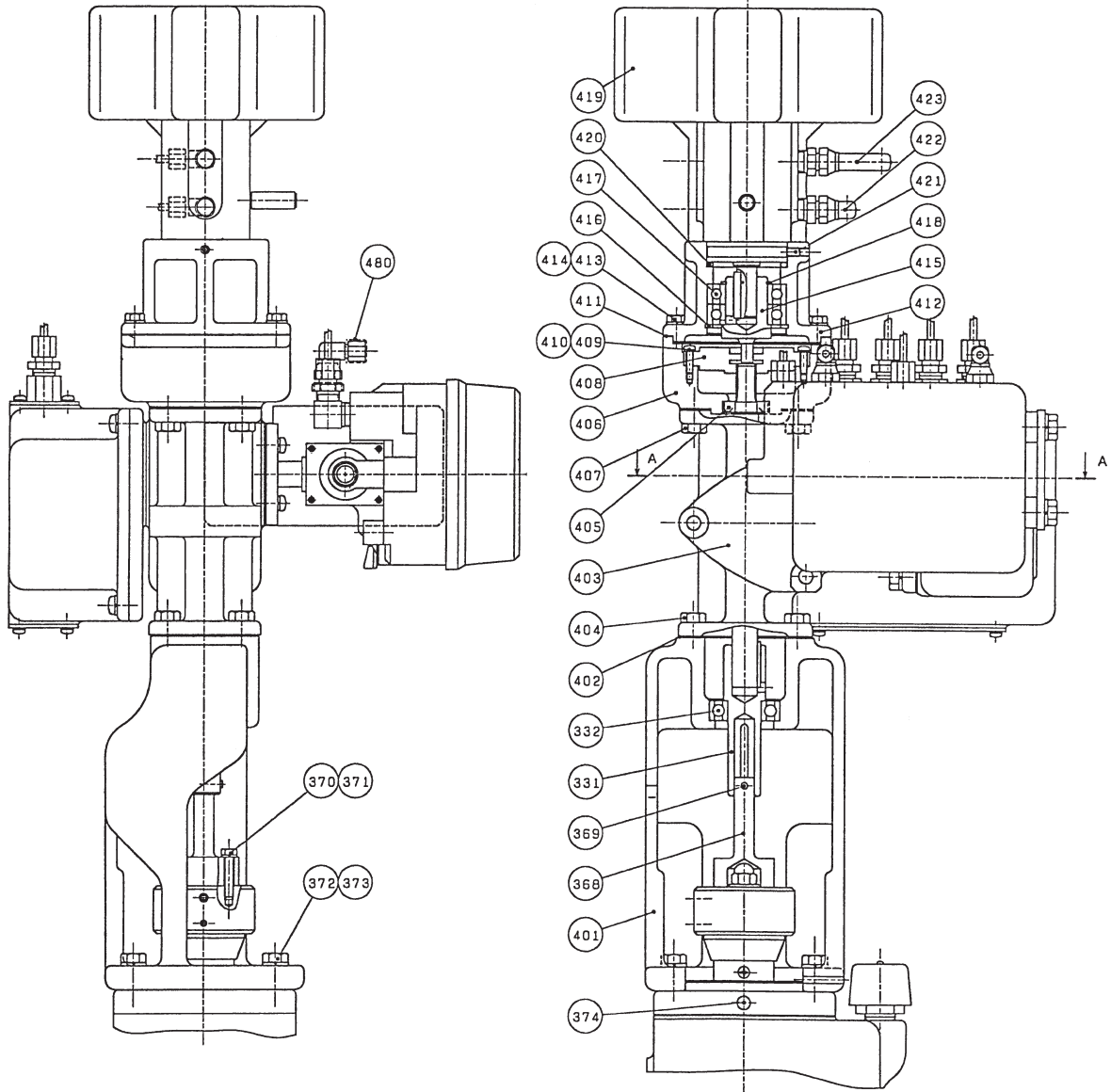

<AXB models>

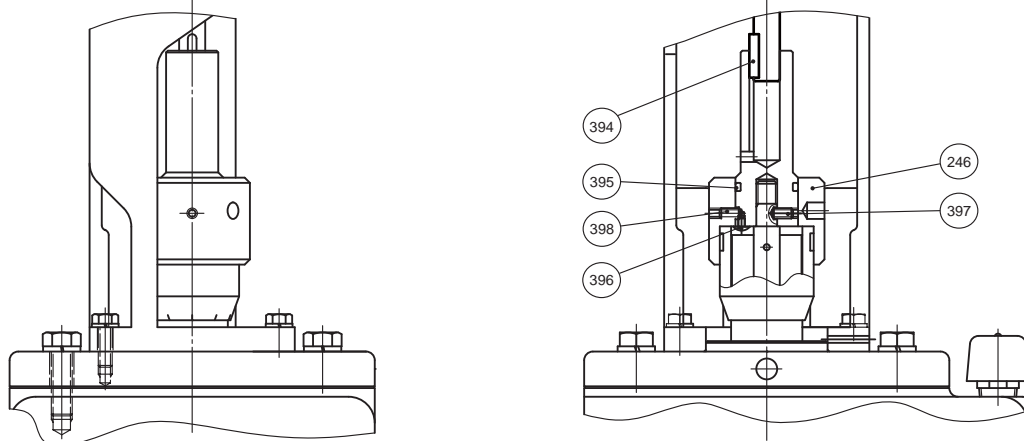

# Maintenance

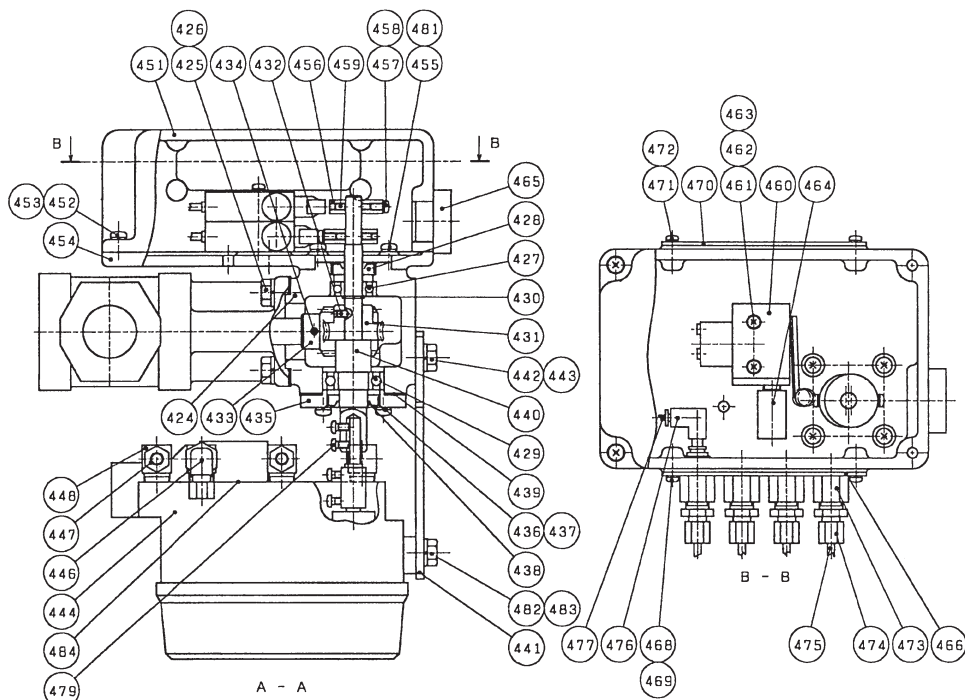

No.	Name	Quantity	No.	Name	Quantity	No.	Name	Quantity
246	Control knob *	1	418	Retaining ring	1	453	Spring washer	4
331	Connecting shaft	1	419	Air motor (with a silencer)	1	454	Box plate	1
332	Deep groove ball bearing	1	420	O-ring	1	455	Machine screw	4
368	Slide shaft	1	421	Hex. socket set screw	2	456	Limit cam	2
369	Spring pin	1	422	Swivel elbow	1	457	Machine screw	2
370	Hex. head bolt	2	423	Swivel long elbow	1	458	Spring washer	2
371	Spring washer	2	424	Servo box	1	459	Hex. socket set screw	2
372	Hex. head bolt	4	425	Hex. head bolt	4	460	Mechanical valve	2
373	Spring washer	4	426	Spring washer	4	461	Machine screw	2
374	Insert-type bumper	1	427	Deep groove ball bearing	1	462	Spring washer	2
394	Key *	1	428	Oil seal	1	463	Plate washer	2
395	O-ring *	1	429	Deep groove ball bearing	1	464	Silencer	2
396	Machine screw *	1	430	Retaining ring	1	465	Air breather	1
397	Hex. socket set screw *	2	431	Servo wheel	1	466	Plate B	1
398	Hex. socket set screw *	1	432	Hex. socket set screw	1	468	Machine screw	4
401	Bracket	1	433	Servowarm	1	469	Spring washer	4
402	Gasket F	3	434	Hex. socket set screw	1	470	Plate C	1
403	Gear box	1	435	Cover	1	471	Machine screw	4
404	Hex. head bolt	4	436	Machine screw	4	472	Spring washer	4
405	Oil seal	1	437	Spring washer	4	473	Bulkhead female connector	4
406	Gear case	1	438	Oil seal	1	474	Half union	4
407	Hex. head bolt	4	439	Gasket D	1	475	Aluminum pipe	0.8m
408	Geared	1	440	Servo shaft	1	476	Reducer elbow	4
409	Machine screw	4	441	Plate A	1	477	Nylon tube	0.7m
410	Spring washer	4	442	Hex. head bolt	2	479	Machine screw	2
411	Gasket E	1	443	Spring washer	2	480	Cap	2
412	Bearing case	1	444	Pneumatic-pneumatic positioner	1	481	Spring washer	4
413	Hex. head bolt	4	446	Swivel elbow	2	482	Hex. head bolt	2
414	Spring washer	4	447	Half union	2	483	Spring washer	2
415	Motor connecting shaft	1	448	PT elbow	4	484	Connecting pipe nameplate	1
416	Retaining ring	1	451	Valve box	1			
417	Deep groove ball bearing	2	452	Machine screw	4			

\*Used with AXB models only.

# Maintenance

- Structural drawing of the electro-pneumatic servo unit

<AXJ, K, A models>

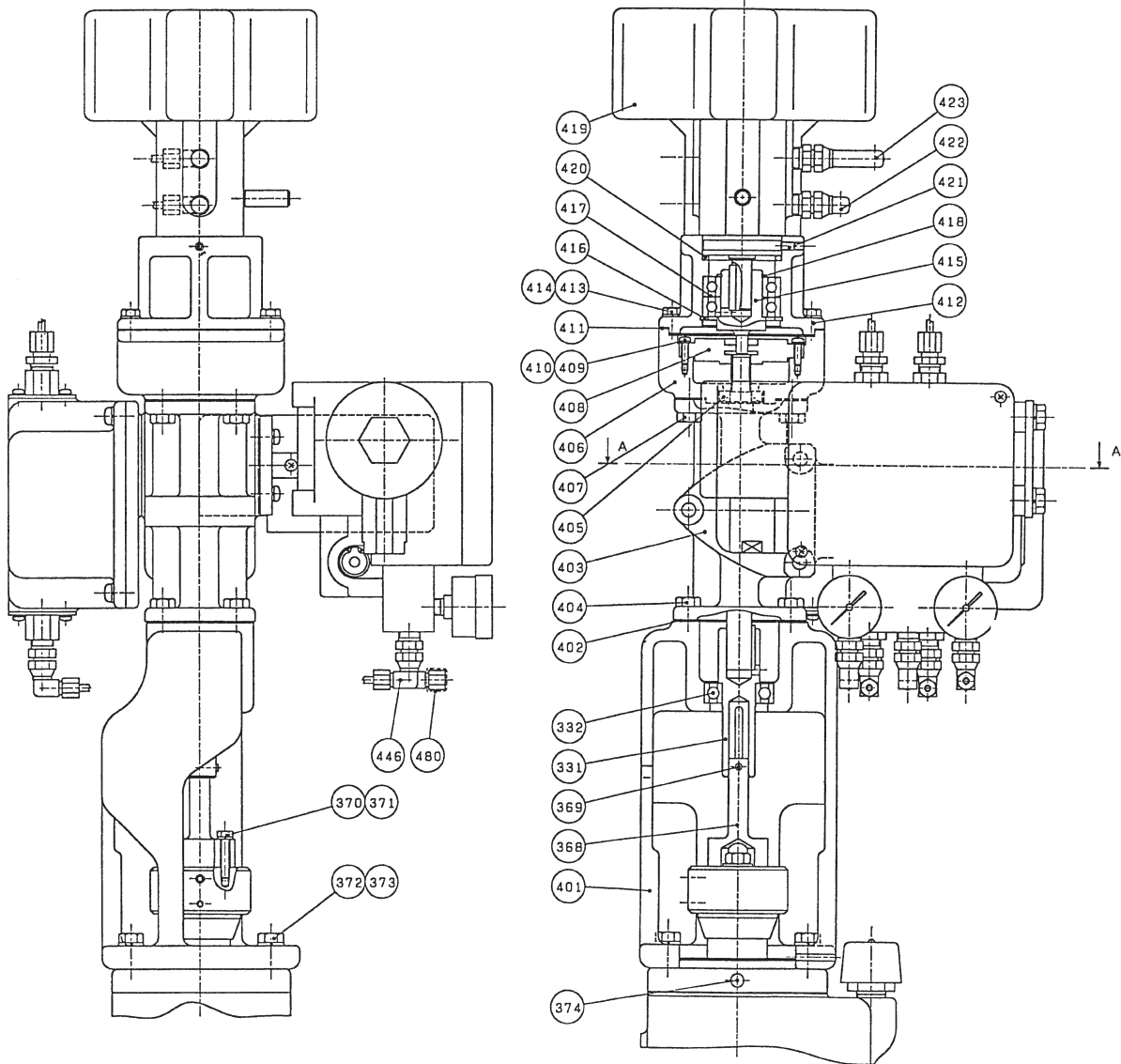

<AXB models>

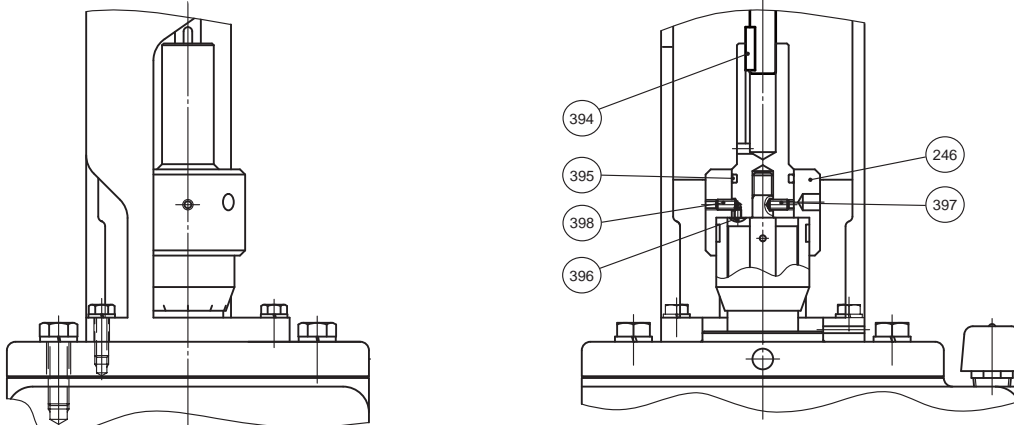

# Maintenance

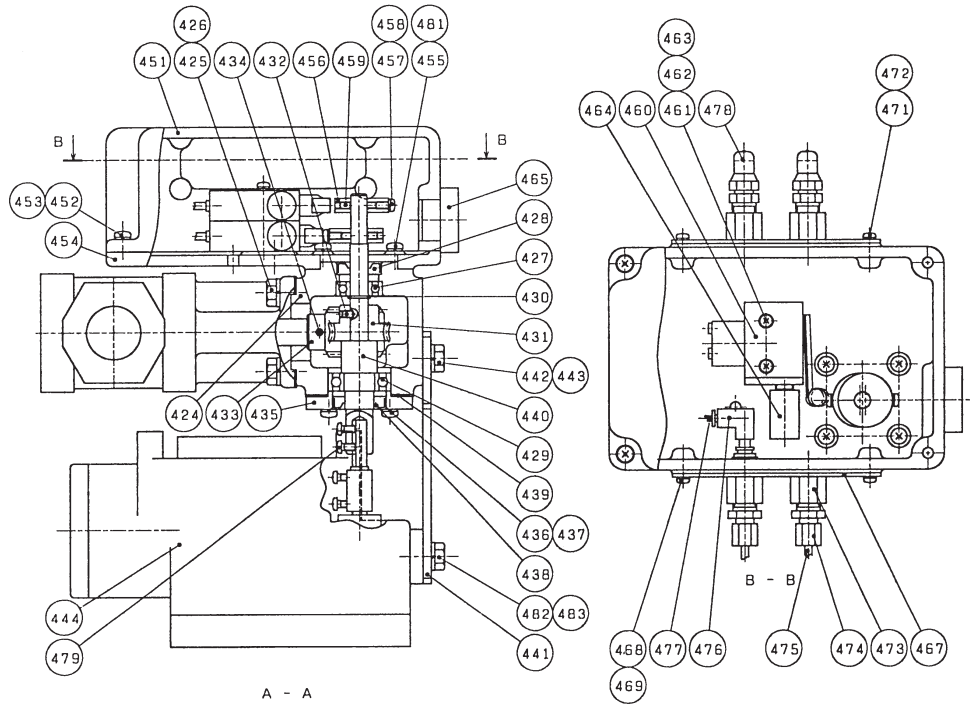

No.	Name	Quantity	No.	Name	Quantity	No.	Name	Quantity
246	Control knob *	1	417	Deep groove ball bearing	2	453	Spring washer	4
331	Connecting shaft	1	418	Retaining ring	1	454	Box plate	1
332	Deep groove ball bearing	1	419	Air motor (with a silencer)	1	455	Machine screw	4
368	Slide shaft	1	420	O-ring	1	456	Limit cam	2
369	Spring pin	1	421	Hex. socket set screw	2	457	Machine screw	2
370	Hex. head bolt	2	422	Swivel elbow	1	458	Spring washer	2
371	Spring washer	2	423	Swivel long elbow	1	459	Hex. socket set screw	2
372	Hex. head bolt	4	424	Servo box	1	460	Mechanical valve	2
373	Spring washer	4	425	Hex. head bolt	4	461	Machine screw	2
374	Insert-type bumper	1	426	Spring washer	1	462	Spring washer	2
394	Key *	1	427	Deep groove ball bearing	1	463	Plate washer	2
395	O-ring *	1	428	Oil seal	1	464	Silencer	2
396	Machine screw *	1	429	Deep groove ball bearing	1	465	Air breather	1
397	Hex. socket set screw *	2	430	Retaining ring	1	467	Plate D	2
398	Hex. socket set screw *	1	431	Servo wheel	1	468	Machine screw	4
401	Bracket	1	432	Hex. socket set screw	1	469	Spring washer	4
402	Gasket F	3	433	Servowarm	1	471	Machine screw	4
403	Gear box	1	434	Hex. socket set screw	1	472	Spring washer	4
404	Hex. head bolt	4	435	Cover	1	473	Bulkhead female connector	4
405	Oil seal	1	436	Machine screw	4	474	Half union	2
406	Gear case	1	437	Spring washer	4	475	Aluminum pipe	0.8m
407	Hex. head bolt	4	438	Oil seal	1	476	Reducer elbow	4
408	Geared	1	439	Gasket D	1	477	Nylon tube	0.7m
409	Machine screw	4	440	Servo shaft	1	478	Swivel elbow	2
410	Spring washer	4	441	Plate A	1	479	Machine screw	2
411	Gasket E	1	442	Hex. head bolt	2	480	Cap	1
412	Bearing case	1	443	Spring washer	2	481	Spring washer	4
413	Hex. head bolt	4	444	Electro-pneumatic positioner	1	482	Hex. head bolt	2
414	Spring washer	4	446	Swivel elbow	3	483	Spring washer	2
415	Motor connecting shaft	1	451	Valve box	1			
416	Retaining ring	1	452	Machine screw	4			

\*Used with AXB models only.







<http://www.iwakupumps.jp>  
IWAKI CO.,LTD. 6-6 Kanda-Sudacho 2-chome Chiyoda-ku Tokyo 101-8558 Japan  
TEL: +81 3 3254 2935 FAX: +81 3 3252 8892

**European office** / IWAKI Europe GmbH  
TEL: +49 2154 9254 0 FAX: +49 2154 9254 48

**Germany** / IWAKI Europe GmbH  
TEL: +49 2154 9254 50 FAX: +49 2154 9254 55

**Holland** / IWAKI Europe GmbH (Netherlands Branch)  
TEL: +31 74 2420011 FAX: +49 2154 9254 48

**Italy** / IWAKI Europe GmbH (Italy Branch)  
TEL: +39 0444 371115 FAX: +39 0444 335350

**Spain** / IWAKI Europe GmbH (Spain Branch)  
TEL: +34 93 37 70 198 FAX: +34 93 47 40 991

**Belgium** / IWAKI Belgium N.V.  
TEL: +32 13 670200 FAX: +32 13 672030

**Denmark** / IWAKI Nordic A/S  
TEL: +45 48 242345 FAX: +45 48 242346

**Finland** / IWAKI Suomi Oy  
TEL: +358 9 2745810 FAX: +358 9 2742715

**France** / IWAKI France S.A.  
TEL: +33 1 69 63 33 70 FAX: +33 1 64 49 92 73

**Norway** / IWAKI Norge AS  
TEL: +47 23 38 49 00 FAX: +47 23 38 49 01

**Sweden** / IWAKI Sverige AB  
TEL: +46 8 511 72900 FAX: +46 8 511 72922

**U.K.** / IWAKI Pumps (U.K.) LTD.  
TEL: +44 1743 231363 FAX: +44 1743 366507

**U.S.A.** / IWAKI America Inc.  
TEL: +1 508 429 1440 FAX: +1 508 429 1386

**Argentina** / IWAKI America Inc. (Argentina Branch)  
TEL: +54 11 4745 4116

**Singapore** / IWAKI Singapore Pte Ltd.  
TEL: +65 6316 2028 FAX: +65 6316 3221

**Indonesia** / IWAKI Singapore (Indonesia Branch)  
TEL: +62 21 6906606 FAX: +62 21 6906612

**Malaysia** / IWAKI SDN. BHD.  
TEL: +60 3 7803 8807 FAX: +60 3 7803 4800

**Australia** / IWAKI Pumps Australia Pty Ltd.  
TEL: +61 2 9899 2411 FAX: +61 2 9899 2421

**China (Hong Kong)** / IWAKI Pumps Co., Ltd.  
TEL: +852 2607 1168 FAX: +852 2607 1000

**China (Guangzhou)** / GFTZ IWAKI Engineering & Trading Co., Ltd.  
TEL: +86 20 84350603 FAX: +86 20 84359181

**China** / IWAKI Pumps (Shanghai) Co., Ltd.  
TEL: +86 21 6272 7502 FAX: +86 21 6272 6929

**Korea** / IWAKI Korea Co., Ltd.  
TEL: +82 2 2630 4800 FAX: +82 2 2630 4801

**Taiwan** / IWAKI Pumps Taiwan Co., Ltd.  
TEL: +886 2 8227 6900 FAX: +886 2 8227 6818

**Thailand** / IWAKI (Thailand) Co., Ltd.  
TEL: +66 2 322 2471 FAX: +66 2 322 2477

**Vietnam** / IWAKI Pumps Vietnam Co., Ltd.  
TEL: +84 613 933456 FAX: +84 613 933399