

IWAKI

Electromagnetic Metering Pump

EHN Series (Standard Model)

Instruction Manual



Read this instruction manual before use of product

Thank you for having selected Iwaki's EHN type electromagnetic metering pump.

This instruction manual, which is divided into 5 sections, namely "Safety Section," "Outline Section," "Installation Section," "Operation Section" and "Maintenance Section," deals with the correct handling and operation procedures for the pump.

You are requested to read this manual prior to using the pump, to ensure safe and long operation.



Contents

Instruction for safety		1~3
Outline of product	1. Unpacking and inspection	4
	2. Principle of operation	4
	3. Model identification	5
	4. Specification	6
	5. Operating function	7
	6. STOP function	8
	7. Overview	8-9
Installation	1. Before installation	10
	2. Precaution on handling	10-11
	3. Installation	12
	4. Tubing	13-14
	5. Electrical wiring	14~18
Operation	1. Operation	19~23
	2. Operation of controller	24~35
Maintenance	Instruction for safety	36
	1. Troubleshooting	36
	2. Maintenance and inspection	37
	3. Wear parts	37
	4. Disassembling and assembling	38~42
Exploded view		43~46
Outline dimension		47-48

Instruction for safety

For the Safe and Correct Handling of the Pump

- Read the "Safety Instructions" sections carefully to prevent accidents involving your customers or other personnel and to avoid damage or loss of other assets. Always follow the instructions and advice found in these sections.
- Observe and abide by the instructions described in this manual. These instructions are very important for protecting pump users from dangerous conditions and situations related with the use of the pump system.
- The symbols relate to the following meanings described below:

 Warning	Nonobservance or misapplication of the contents of the "Warning" section could lead to a serious accident, including death or injury.
 Caution	Nonobservance or misapplication of the contents of the "Caution" section could lead to serious physical injury to the user or serious damage to the product.

Types of Symbols



Indicates a prohibited action or procedure. Inside or near this circle, a concrete and practical image of the activity to be avoided is depicted.



Indicates an important action or procedure which must be performed or carried out without fail. Failure to follow the instructions herein can lead to malfunction or damage to the pump.

Instruction for safety

Warning

- **Turn off the power supply.**
Working without disconnecting the power supply may cause an electrical shock. Before engaging upon any working procedures involving the pump, make sure to turn the power supply switch off and to stop the pump and other related devices.
- **Terminate operation**
When you detect or become aware of a dangerous sign or abnormal condition during operation, terminate the operation immediately and start it from the beginning again.
- **For specified application only.**
The use of a pump in any application other than those clearly specified may result in injury or damage to the pump. Use the pump strictly in accordance with the pump specifications and application range.
- **No remodeling**
Never remodel or modify a pump. Otherwise, a serious accident may result. IWAKI will not be responsible for any accident or damage of any kind which is caused by the user remodeling the pump without first obtaining permission or instructions from Iwaki.
- **Wear protectors.**
If you touch or come in contact with any type of hazardous chemical liquid, including but not limited to chemicals, you may experience a serious injury. Wear protector (protective mask, gloves, etc.) during the works.



Caution

- **Qualified operators only**
The pump operator and pump operation supervisor must have the knowledge of the pump to operate the pump.
- **Specified power only.**
Do not operate the pump with voltage which is not specified on the nameplate. Otherwise damage or fire will may happen. Only the specified power source must be used.
- **Pay attention to dry running.**
Do not run pump dry for more than 30 minutes. If pump runs dry for more than 30 minutes, screws of pump head will be loosened and may result in liquid leakage. Install the pump so that dry running can not occur. Also, when bleeding is done, do not run pump dry for more than 30 minutes.
- **Do not wet or dampen.**
If an electric part or wiring gets wet with the liquid spilled over accidentally, a fire or electrical shock may be caused. Install the system in a place free from liquid spillage or leakage.
- **Ventilate.**
Poisoning may result during an operation which involves toxic or odorous liquid. Ventilate the operating site sufficiently.



Instruction for safety

Caution

- **Limited operating site and storage**
Do not install or store the pump in the following places:
 - * Places where a flammable gas or material is used or stored.
 - * Places where the ambient temperature is extremely high (40 dig.C or higher) or extremely low (0 dig.C or lower).
- **Spill-out accident**
Protective measures should be taken against any accidental spill-out or leakage of the operating liquid as a result of unexpected damage on the pump or the related piping.
- **Humid place prohibited**
The pump is not water-proof construction. If the pump is used at place where liquid is splashed on pump or at humid place, electrical shock or short-circuit may happen.
- **Do not damage or change power cable.**
Do not scratch, damage, process, or pull the power cable forcibly. An extra load onto the cable, such as heating the cable or placing something heavy on the cable, may damage the cable and finally cause a fire or an electrical shock.
- **Arrange grounding.**
Do not operate the pump without connecting the grounding wire. Otherwise, an electrical shock may result. Make sure the grounding wire is connected with the grounding terminal.



Prohibited



Caution



Prohibited



Caution



Grounding

Caution

- **Install an earth leakage breaker (option).**
The operation of a pump without using an earth leakage breaker may cause an electrical shock. Please purchase an optional leakage breaker and install in the system.
- **Handling of power cable**
Use of a defective or damaged power cable may result in a fire or electrical shock. Handle the power cable carefully.
- **Follow the instruction manual.**
Replace the consumable parts by following the descriptions in the instruction manual. Do not disassemble the pump beyond the extent shown on the instruction manual.
- **Damaged pump**
Never operate a damaged pump. A damaged pump may cause leakage or electrical shock.
- **Disposal of used pump**
Disposal of used or damaged pumps must be done in accordance with the relevant local laws and regulations. (Consult a licensed industrial waste products disposing company.)



Electrical Shock



Electrical Shock



Prohibited



Outline of product

1. Unpacking and inspection

- 1) Check model code, discharge capacity, discharge pressure and voltage etc. shown on nameplate.
- 2) Check if accessories are attached.
 - a. Check valve or back pressure valve : One piece

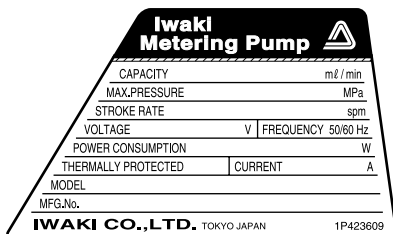

Model	Set press. MPa	Connection mm	Wet-end material	Applied pump model	Pump wet-end material code
Check valve	0.17	Ø 4 × Ø 9	GFRPP	EHN-B10-15-20	PC
				EHN-C15-20	PH
				EHN-C30	PC
				EHN-C35	PH
	0.05	Ø 8 × Ø 13	GFRPP	EHN-B30	PC
				EHN-C35	PH
				EHN-B10-15-20	VC
				EHN-C15-20	VH
	0.17	Ø 4 × Ø 9	PVC	EHN-B10-15-20	VC
				EHN-C15-20	VH
				EHN-C30	VC
				EHN-C35	VH
	0.05	Ø 8 × Ø 13	PVC	EHN-B30	VC
				EHN-C35	VH

- b. Hose for tubing 3 m × 1 pc (4 × 9 dia. or 8 × 13 dia. PVC braided hose)

Note: EVA hose (4 × 9 dia. or 8 × 13 dia. PVC braided hose) is attached for type PP.

- 3) Check if product is not damaged, if any parts are not lost during transportation or if any bolts or nuts are not loosened during transportation. If you find any abnormality, ask your supplier.

2. Principle of operation

IWAKI electromagnetic metering pump EHN series is diaphragm type metering pump of which diaphragm is directly driven by electromagnetic force consisting of pump head, driving unit and control unit. Reciprocating movement is made by the force of spring and electromagnet generated by pulse current coming from control unit. The reciprocating movement is transferred to diaphragm which is connected to plunger to make volumetric change in pump chamber. Pumping effect is obtained by the volumetric change and by the effect of valve which is mounted in pump head.

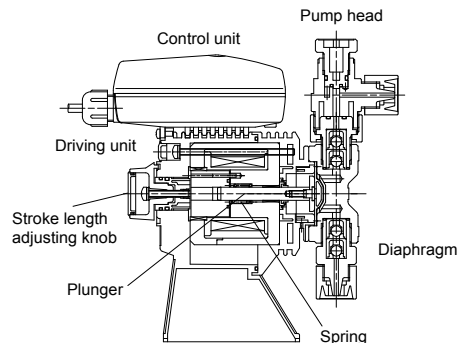

Outline of product

3. Model identification

Pump : **EHN - B 10 VC 1 R - □□**
 1 2 3 4 5 6 7

1. Series

EHN multi voltage type

2. Driving unit code (Average power consumption)

B : 20W

C : 24W

3. Diaphragm effective diameter

10 : 10mm

15 : 15mm

20 : 20mm

30 : 30mm

35 : 35mm

4. Wet-end material

Code	Pump head	Valve ball	O ring	Valve seat	Gasket	Diaphragm
VC	PVC	Ceramic	FKM	FKM	PTFE	PTFE + EPDM (Not wet-end)
VH		Hastelloy C	EPDM	EPDM		
PC	GFRPP	Ceramic	FKM	FKM		
PH		Hastelloy C	EPDM	EPDM		
PP		Ceramic	FKM	PCTFE		

Material code PVC : Transparent polyvinyl chloride

GFRPP : Glass fiber reinforced polypropylene

EPDM : Ethylene propylene rubber

FKM : Fluor rubber (Acid resistant Viton®)

PTFE : Poytetrafluoro ethylene

5. Connection hose diameter code

No.	Connected hose dia.	Kind	Remarks
1	4 × 9 dia.	Transparent PVC braid hose	
2 (Note)	4 × 6 dia.	Teflon or polyethylene hose	
3 (Note)	6 × 8 dia.	Teflon or polyethylene hose	Only for VC,VH
4	8 × 13 dia.	Transparent PVC braid hose	
5 (Note)	9 × 12 dia.	Teflon or polyethylene hose	

(Note) Special specification. Standard for others.

6. Controller function code

R: Standard type

7. Special type code

01 ~ 99 : Non standard material, non standard connection or so.

Control unit : **EHNC - B R - □□**
 1 2 3 4

1. Control unit type

EHNC: Multi voltage type (with crimp contact)

2. Driving unit code

B or C

3. Controller function code

R: Standard type

4. Special type code

01 ~ 99 : Non standard specification.

Outline of product

4. Specification

4-1. Pump specification

- PVC/PP types (VC, VH, PC, PH and PP)

Model	Disch. capacity ml/min	Max. disch. press. MPa	Stroke length mm (%)	Stroke rate spm	Connection hose size mm	Average power consumption W	Mass kg
EHN-B10	38	1.0	0.5~1.0 (50~100)	1~360	∅ 4 × ∅ 9	20	1.8
EHN-B15	65	0.7					
EHN-B20	100	0.4					
EHN-B30	230	0.2	0.5~1.25 (40~100)	1~360	∅ 8 × ∅ 13	24	2.9
EHN-C15	80	1.0			∅ 4 × ∅ 9		
EHN-C20	130	0.7					
EHN-C30	270	0.35			∅ 8 × ∅ 13		
EHN-C35	450	0.2					
EHN-B30PP	230	0.2	0.5~1.0(50~100)	20		1.8	

Note 1. Performance is obtained by pumping clean water at ambient temp. at rated voltage.

2. Discharge capacity is the value at max. discharge pressure (100% stroke length, 360 spm stroke rate). When discharge pressure is low, pump discharges liquid much more than discharge capacity shown as above.
3. Permissible ambient temperature : 0 ~ 40 deg. C
4. Permissible liquid temperature : 0 ~ 40 deg. C (0 ~ 60 deg. C for PC, PH & PP)
5. B20 and C15 are not available for type PP.
6. Permissible voltage fluctuation : Within ±10% of rated voltage

Note: Ask us or our distributor for special case such as transferring slurry liquid or so.

Note: Specification may be changed without prior notice for the improvement.

4-2. Control unit

Operation mode	Mode	Manual
	Switching	EXT(Pulse dividing or multiply)
Stroke rate	Set range	1 ~ 360 spm
	Set method	Up or down key
	Memory function	By non-volatile memory
STOP input	When M - OFF	Pump stops when contact signal comes.
	When M - ON	Pump runs when contact signal comes.
	Input signal	Potential free contact or open collector (Note.1)
EXT input	Upper limit stroke rate	Stroke rate indication of manual mode
	Pump operation	1 input signal : "n" pumping(s) (Pulse multiply) Note 2. "n" input signal(s) : 1 pumping (Pulse dividing) Note 3. *When "n" is 1, the pump starts synchronized operation
	Input signal	Potential free contact or open collector (Note 1.)
	Dividing ratio/Multiply ratio setting range	1~999 (Dividing or multiply)
Display	Figures	4 digits LCD
	Pump movement	Green LED (one) (Blinks synchronous with pump operation)
Power source voltage		AC100V~240V, 50/60Hz

Note 1. : Max. charged voltage to contact is 12V and 5mA current. If contact such as relay is used, its applicable load should be 5mA or below.

Note 2. : The input signals over the upper limit stroke rate are stored up to 255 signals.

Note 3. : The residual input signals over 360 spm are cancelled.

Note 4. : Do not apply any voltage other than the specified one. It causes the pump failure.

Outline of product

5. Operating function

5-1. Manual operation

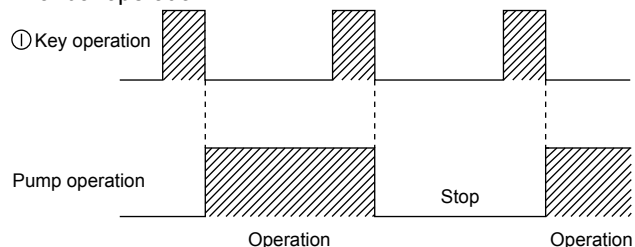

With (UP) and (DOWN) keys, set stroke rate for 1 ~ 360 spm range and with (Stop/start) key start and stop pump. Setting of stroke rate can be done while pump is running or stops.

5-2. EXT operation

EXT input (Multiply) when a set number of pumping is 5

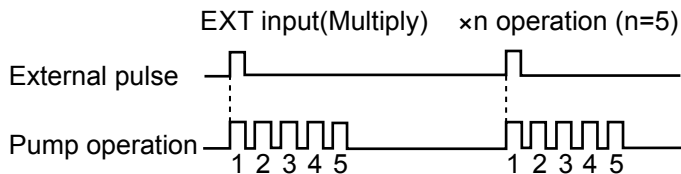

EXT input operation (Pulse multiply)

Pump operates with a set number of pumping between 1~999 for a external pulse signal. The preset stroke rate in manual operation is applied as the upper limit stroke rate in EXT operation. The pulse signals which come while pumping for the set number of times for a external pulse signal are stored up to 255 pulses. When the set number of pumping is set to 1, pump operates synchronously with a external pulse in the ratio of 1:1.

EXT input (Dividing) when a set number of pumping is 5

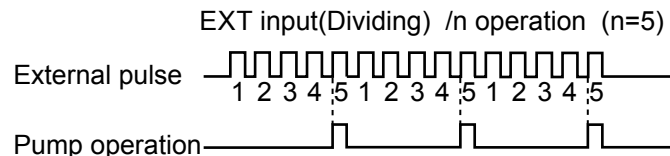

EXT input operation (Pulse dividing)

Pump operates with a pumping for external pulse signals. The preset stroke rate in manual operation is applied as the upper limit stroke rate in EXT operation. Residual input signals over 360 spm are cancelled. When the set number of external signals is set to 1, pump operates synchronously with a external pulse in the ratio of 1:1.

Caution

When the set number of external pulse signals for a pumping is set to 1 in pulse dividing operation, pump operation can be unstable due to the residual signal cancellation function but it is not malfunction of pump. Set the number of pumping for a external pulse signals to 1 for 1:1 operation in the pulse multiply operation.

Outline of product

6. STOP function

6-1. At M – OF setting

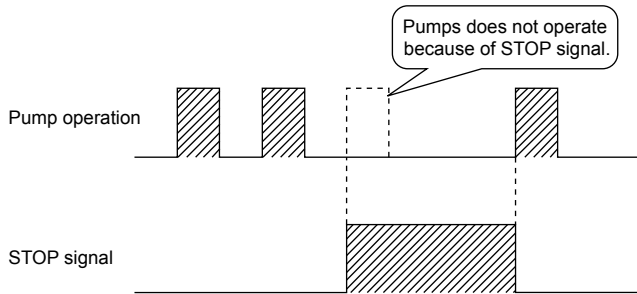

When STOP signal comes (contact closed), stop pump.
When STOP signal is cancelled, pump operates.

6-2. At M – ON setting

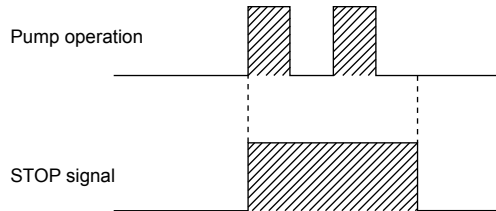

Pump operates while STOP signal comes (contact closed). When pump operates in EXT mode, pump operates synchronous with EXT input only while STOP signal is coming.

7. Overview

7-1. Overview of pump

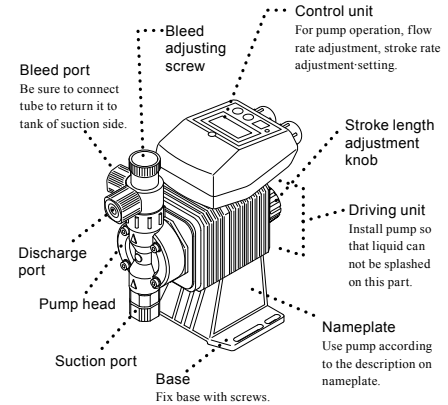

Outline of product

7-2. Overview of controller

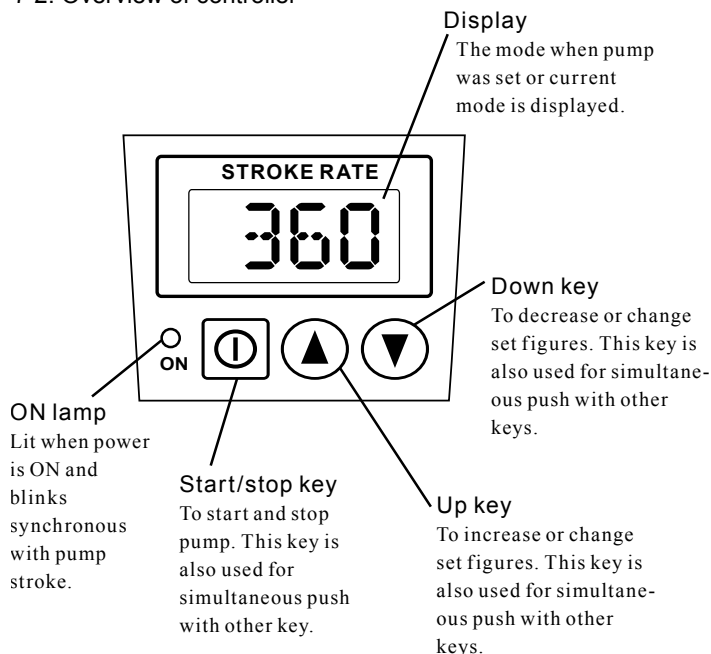

	ON lamp lights.	ON lamp blinks.
360	Waiting in manual operation mode.	Running in manual operation mode. The display blinks as well.
EXT	Waiting EXT input in EXT mode.	Running synchronously with EXT input in EXT mode.

7-3. Basic display.

	ON lamp lights.	ON lamp blinks.
STOP	STOP function is operating.	
-STOP	STOP function is operating in manual waiting mode.	
T-5	Chattering is being set. T-10 or T-50 may be displayed.	
/NNN	Pulse dividing is selected in the selection display.	
XNNN	Pulse multiply is selected in the selection display.	
/ 5	The dividing ratio of EXT mode is being set. The left display shows 1 pumping for 5 pulses.	
X 5	The multiply ratio of EXT mode is being set. The left display shows 5 pumping for a pulse.	
M-OF	STOP input is set. M-ON may be displayed.	
OVER	EXT input exceeds the pump upper limit spm in EXT mode. Pump operates at its upper limit spm.	EXT input is exceeding the pump upper limit spm in EXT mode. Pump is operating at its upper limit spm.
.360		Pump is running with pulse dividing/multiply operation for external input pulses. The indication shows pump operation spm.
⌘ 360 (Lock)	Key is locked. Key operations are ineffective in this state. Release the key lock function before operation.	Key is locked. Key operations are ineffective in this state. Release the key lock function before operation.

Installation

1. Before installation

"Strictly observe the following points."

Operators and maintenance service staff must read the instruction manual thoroughly before using the products. Do not operate the pump system unless all of the contents in the manual are completely understood.

Warning

- **Turn off the power supply**
Working without disconnecting the power supply may cause an electrical shock. Before engaging upon any working procedures involving the pump, make sure to turn the power supply switch off and to stop the pump and other related devices.
- **Terminate operation**
When you detect or become aware of a dangerous sign or abnormal condition during operation, terminate the operation immediately and start it from the beginning again.
- **Specified power only.**
Do not operate the pump on voltage which is not specified on the nameplate. Failure to do so may result in damage or fire. Only the specified power level is to be applied.
- **Keep from heat or flame.**
Do not place any dangerous materials or flammable objects near the pump for the prevention of fire or accident.
- **Damaged pump**
Never operate a damaged pump. A damaged pump may cause leakage or electrical shock.

2. Precaution on handling

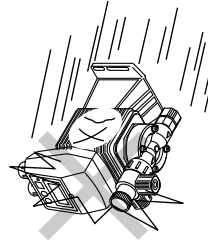

- Dropping the pump or subjecting it to strong impacts may result in faulty performance. Handle the pump with care.

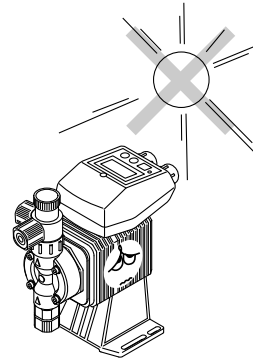

- When installing the pump, avoid places exposed to direct sunlight or direct rain with an ambient temperature of above 40 deg.C, or with a relative humidity of above 85%. Though the pump has a simple waterproof and dustproof structure, do not install it outdoor.

- Select an installation site convenient for future maintenance and inspection, and fix the pump on a level floor so that it is free of vibrations.

Installation

- **Ventilate.**

Poisoning may result during an operation which involves toxic or odorous liquid. Ventilate the operating site sufficiently.



- **Do not wet or dampen.**

If an electric part or wiring gets wet with the liquid spilled over accidentally, a fire or electrical shock may be caused. Install the system in a place free from liquid spillage or leakage.



Prohibited

- **Install an earth leakage breaker (option).**

The operation of a pump without using an earth leakage breaker may cause an electrical shock. Please purchase an optional leakage breaker and install in the system.

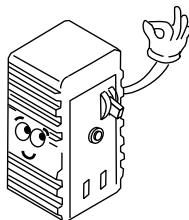

Prohibited

- **The control unit can be detached.** However, it should not be detached unless unavoidable. Never use the detached control unit with the pump models other than the one delivered.



Caution

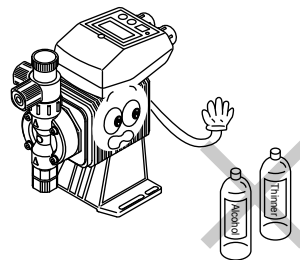

- **Arrange grounding.**

Do not operate the pump without connecting the grounding wire. Otherwise, an electrical shock may result. Make sure the grounding wire is connected with the grounding terminal.

- **Limited operating site and storage**

Do not install or store the pump in the following places:

- * Places where a flammable gas or material is used or stored.
- * Place where the ambient temperature is extremely high (40 deg.C or higher) or extremely low (0 deg.C or lower).

- **Cleaning**

Wiping the pump body or the nameplate with a cloth soaked in a solvent such as benzene, thinner or kerosene may remove or change the colour of the coating. Use a dry cloth or a cloth soaked in water or neutral detergent.

Installation

3. Installation



Caution

- When you detect or become aware of a dangerous sign or abnormal condition during operation, stop the operation and restart the procedure from the beginning.

• Installation

Install the pump at a site where the ambient temperature does not exceed 40 deg.C and the relative humidity does not exceed 85%. (There should be no dew condensation inside the control unit.) The site must be selected keeping in mind ease and efficiency for maintenance and inspection work.

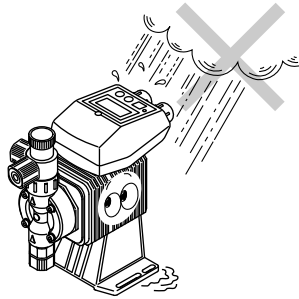

- Place the pump as close to the suction tank as possible, realizing a flooded suction system (where the pump is located lower than the suction-side tank).



Caution

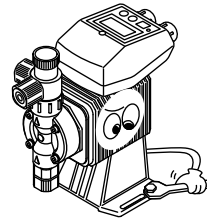

Side view of tube

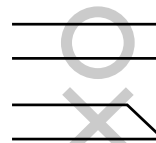

- If the pump is used to feed liquid that generates air bubbles easily (sodium hypochlorite, hydrazine solution, etc.), it must be positioned in a cool, dark place away from direct sunlight.

• Anchoring pump

Select a level floor free of liquid splash, and use M5 screws to firmly anchor the pump so as not to allow any vibration. If the pump is inclined, the discharge amount may be decreased considerably and may even reach the zero level.

• Preparation of tube

Before the installation of the pump, cut the ends of the tube flat.

Installation

4. Tubing

- 1) Insert hose to the bottom, tighten fitting nut by hand and then turn it by 1/2 turns with wrench. Mount hose securely so that liquid can not leak and air can not be sucked in.

Caution

Fitting nut is made by plastics. It may be broken if tightened excessively.

- 2) Connect attached bleed hose to bleed port. Return hose end to suction tank.
- 3) Adjust direction of bleed port. The port can be directed freely.
 - a. Loosen lock nut at the bottom of bleed body by turning it left with wrench.
 - b. Direct bleed port.
 - c. Tighten lock nut by turning it right holding bleed body A by hand.
 - d. Further tighten lock nut by 1/4 turns to right with wrench.

Note: EHN-30-35 types (excluding PP type) are not equipped with bleed valve. Mount bleed valve available as option. (Refer to picture on right.)

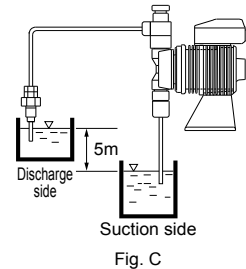
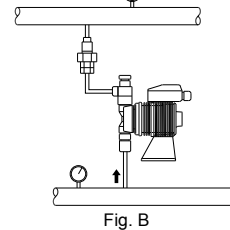
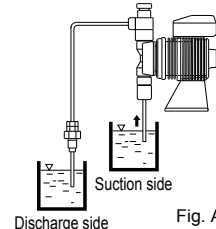
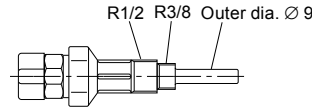
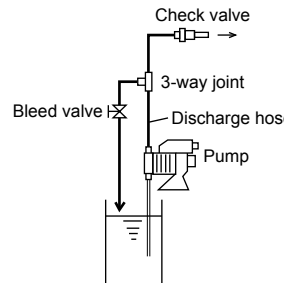
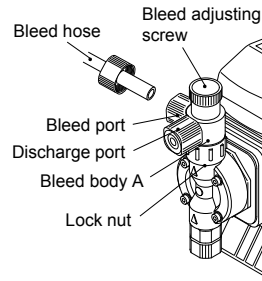
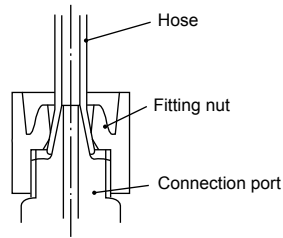

4) Mounting check valve

A check valve is packed to avoid over feeding. Be sure to install the check valve in case of following condition.

- a. In case liquid level of suction side is higher than liquid level of discharge side. (See Fig. A)
- b. In case the pressure of suction side is higher than that of injection point. (See Fig. B.)
- c. In case liquid level height difference is 5 meters or less, even if discharge side liquid level is higher than suction side. (See Fig. C.)

Caution

Wash or replace by new check valve periodically because it may be clogged by crystal.

Installation

d. In case discharge side pressure is below 0.13MPa (pipe resistance or discharge head etc.) (0.049MPa for B30 and C35 models).

* Check valve must be installed at tube end of discharge side apart from 1 meter from pump.

* Threaded connection of R1/2 or R3/8 is also available with CA type check valve and BVC type back pressure valve. Cut to use R1/2 or to use R3/8 as shown on fig. on right. (Refer to item of Accessory for applicable pump models.)

* Also available as option are CB type check valve and BV type back pressure valve on which braid hose can be fitted on both inlet and outlet sides. Ask us for details.

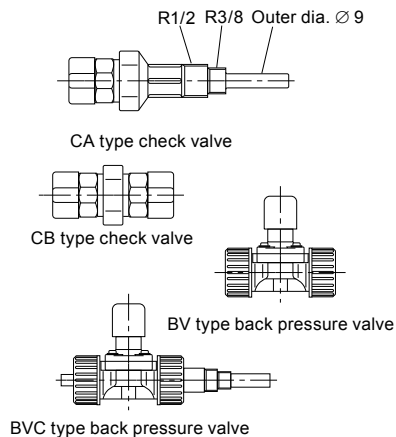

5. Electrical wiring



Electrical works and handling of power source must be done by qualified person. Otherwise injury or damage may happen.

5-1. Wiring of power source

- 1) Before works confirm that main power source is turned off.
- 2) Wiring must be done according to your electrical works standard using good wiring equipment/device.

Caution

Power voltage must be charged at a sitting via switch or relay. Otherwise malfunction of CPU may happen.



When power is charged at a setting

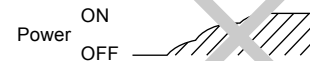

When power is charged gradually

For the relay to be used, refer to P16 which mentions the precaution when pump is controlled by relay ON/OFF.

Installation

Caution

Never put other voltage than rated voltage. Otherwise electronic circuit may be broken.

3) Be sure to connect ground wire.

4) Do not use the same plug socket as high power equipment which may generate surge voltage. Otherwise electronic circuit may be failed. Pay attention to noise generated by inverter or so.

- Surge voltage

Caution

Electronic circuit of control unit may be failed by extremely large surge voltage. Do not use the pump near to the high power equipment of 200V or more which may generate large surge voltage. If use of high power equipment is inevitable, take any of the following measures.

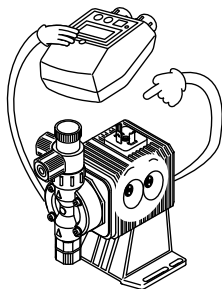
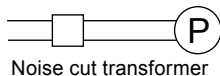
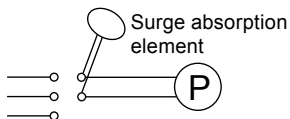

a. Install surge absorption element (Varister or so of 2000A or more durability) at pump power connection part.

b. Install noise cut transformer.

5) Control unit can be removed easily from pump driving unit. Never mount the controller once removed from the different model of pump. Otherwise electronic circuit or driving unit may be damaged.

- Precaution when pump power is turned ON and OFF by relay.

Caution

Control unit is equipped with CPU. It is recommended to stop pump through STOP input terminal but not by switching ON/OFF of power source because switching ON and OFF of power may cause malfunction of CPU. When the use of ON/OFF of power can not be avoided, pay attention to following points.

In case power is ON and OFF by relay, its contact volume must be 5A or more. If relay of 5A or below is used, the contact point may be welded.

If the relay of contact point volume 5A is used for EHN, it can be used for max. 150 thousands times ON and OFF. If you expect more than 150 thousands times or if same power source as large capacity equipment is used, the contact may be welded by surge voltage. In this case use the relay of contact volume of 10A or more. If you will be suffering from durability of relay, use non contact transistor relay (ex. G3F made by OMRON or so). For details refer to catalogue or other documents of equipment manufacturer.

Installation

5-2. Wiring of external input signal

Caution

Never connect wires while power is turned on. Otherwise you may be electrically shocked or controller may be short-circuited. Turn off power when wiring works are done.

Caution

Do the works one minute after the power is turned off because electricity is charged inside pump just after the power is turned off.

External signal

EXT function : Stroke rate can be controlled by pulse signal.
STOP function : Pump can be ON and OFF by external signal.

Use either one of potential free contact signal or open collector signal for external signal. In case of pulse signal is used, pulse width should be 10 ms to 100 ms with pulse rate of 360 pulses/minute or below.

Caution

- Wiring of EXT and STOP
Do not combine cable of EXT and STOP with power cord. Do not wire power source and EXT, STOP signal combined by concentric cable (5 wires cable or so). Otherwise noise is generated in EXT, STOP wires caused by induction effect from power cable, which results in wrong operation or failure of pump.
- When using SSR (solid state relay) for EXT/STOP signal input
When using SSR for EXT/STOP signal input, use the recommended products stated below. SSR which is other than recommended can cause malfunction.
 1. G3FD-102 S or G3FD-102SN made by OMRON
 2. G3TA-IDZR02S or G3TA-IDZR02SMRefer to information materials such as catalogue of manufacturer for further information.
- When using type device for EXT/STOP signal input
When using type device such as relay for EXT/STOP signal input, select some device of which minimum application load is 5mA or below.

Installation

- Wiring procedure

Caution

Used cord must be 7.8 mm of outer diameter. If other diameter of cord is used, perfect connection or sealing can not be obtained, which may result in malfunction of electronic circuit.

- 1) Remove gasket (A) of top of control unit and then remove screw (B), gasket (C) and two screws (D) which are above stroke length adjusting knob to remove the control unit.
- 2) Remove four screws (E) at the bottom of control unit to remove controller cover.
- 3) Remove cord nut (F) for signal cord and remove protective cap (G). The cap (G) is not used when cord is connected. Pull cord gasket (J) out of controller unit.
- 4) Put cord nut (F) and cord gasket (J) on external signal cord and enter the signal cord into control unit.

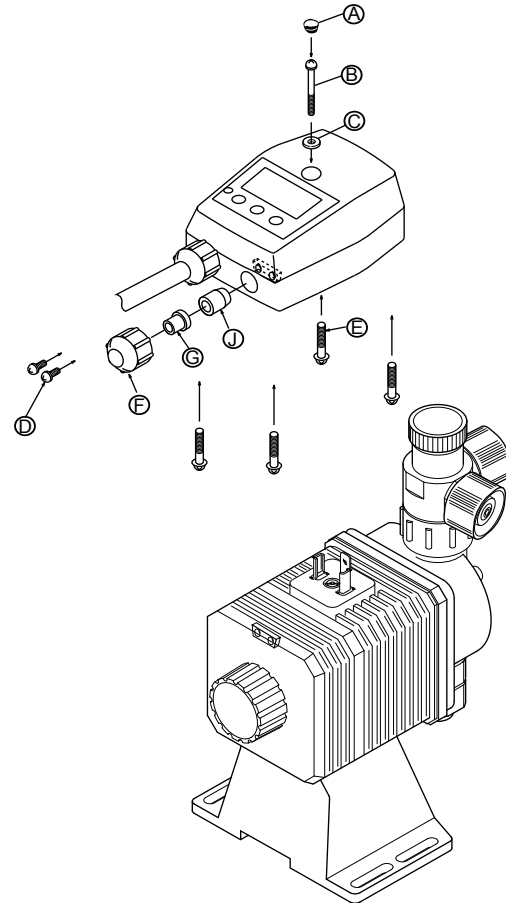

Installation

- 5) Remove plug ④ from socket ①. Connect signal cord to the plug ④ with screw driver and mount it on the socket ①. Pull the signal cord from outside of control unit to adjust the slack and then mount the cord nut ⑤ securely by hand. (The cord is sealed by cord gasket ⑥.)

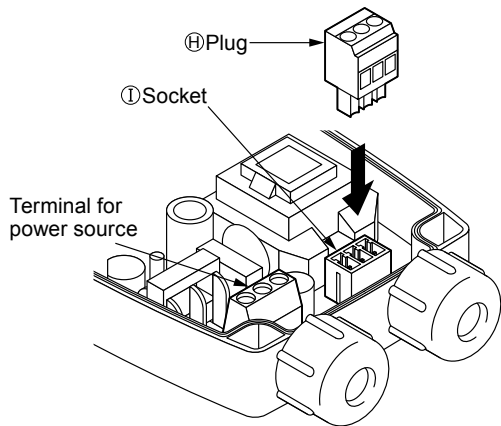

- 6) Mount control cover and mount the controller in the reverse procedure of above items 1) and 2).

Tightening torque of each screw is as follows:

Screw B : 0.39N.m

Screw D : 0.4N.m

Screw E : 0.8N.m

Caution

Do not forget to mount gaskets A and C. Without them, liquid may get into controller and controller may be failed.

Wiring to socket ① for signal input

Potential free contact signal

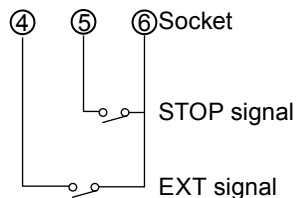

Open collector signal

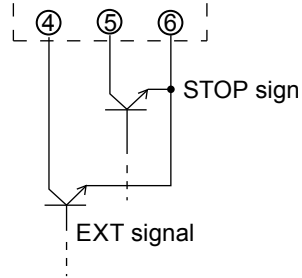

Operation

1. Operation

After the installation, piping, and wiring processes are completed, operate the pump in accordance with the following steps.



Caution

- **Do not operate pump with a completely closed discharge-side valve.**
Operating the pump with the discharge-side valve fully closed may lead to liquid leakage or pipe rupture. Make sure not to operate the pump with the discharge-side valve closed.
- **Do not run pump dry.**
A pump which has been run dry may experience liquid leakage during its liquid feeding operation. Make it a rule to run the pump after supplying liquid inside the pump.
* Dry operation of the pump over a long time (longer than 30 minutes) causes the pump to overheat and the pump unit (pump head, valve case, etc.) to become deformed or the pump head attachment to become loose, which may result in liquid leakage trouble.
- **Re-tighten bolts of pump head**
Loosened bolts on pump head may cause liquid leakage. To avoid liquid leakage caused by loosened bolts, periodically tighten four hex. socket head bolts in diagonal order. Also at the time of initial operation of pump, tighten four bolts diagonally because the bolts may be loosened during storage or transportation.

Tightening torque

Model	Torque	Remarks
EHN-B10 15 20	2.16N m	M4 hex. socket head bolts
EHN-B30	2.55N m	M4 hex. socket head bolts
EHN-C15 20	2.16N m	M4 hex. socket head bolts
EHN-C30	2.55N m	M4 hex. socket head bolts
EHN-C35	2.55N m	M5 hex. socket head bolts

To start and stop pump

1) Turn on power.

Turn on power and ON lamp (green) lights to come to waiting mode in manual mode. (When power is turned on initially.) Display shows stroke rate.

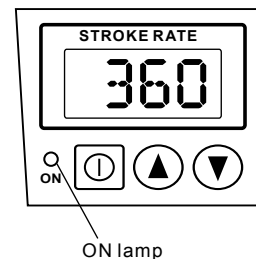

2) Push key once and pump starts operation and both ON lamp and stroke rate indication blink synchronously with pump stroke.

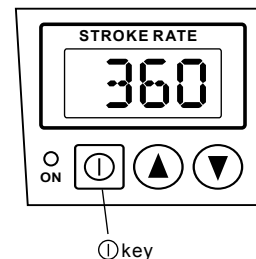

Operation

1-1. Bleeding

Bleeding is a process undertaken to eliminate air inside the suction-side tube and the pump head. Make sure to carry out bleeding prior to the initial operation of the pump and/or after replacing the liquid in the tank. For safe bleeding, first set a pipe to the air-vent port of the air vent unit.

Caution

Some liquids used in pump feeding may cause skin trouble or affect the quality of a mechanical part. Wipe off the liquid immediately when it wets your hand or a mechanical part.

Warning

Both air and chemical go out together from the end of bleeding tube. Return the bleeding tube to chemical tank or other vessel.

- Bleeding for:
EHN-()10, 15, 20 VC, VH, PC, PH & PP types

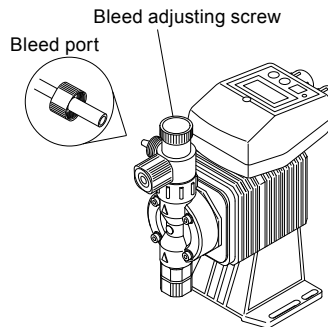

- 1) Start pump. Lamp blinks to show pump operation.
- 2) Adjust pump stroke rate to 360 spm.
- 3) Turn a bleed adjusting screw to left by half turn to open bleed port.
- 4) Run pump for ten minutes to bleeding.
- 5) Turn the bleed adjusting screw to right to close bleed port.
- 6) Check no liquid leaks through parts.

Operation

- Bleeding for:

EHN- ()30, 35 VC, VH, PC & PH types

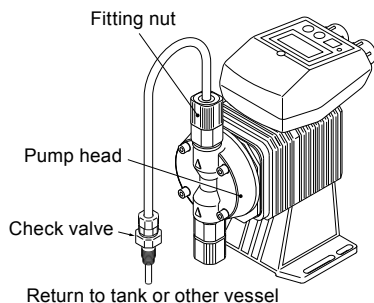

- 1) Return hose which is connected to discharge port of pump to the chemical tank or other vessel and start pump. Remove a check valve of discharge side if it is installed.
- 2) Adjust stroke rate to 360 spm and operate pump for ten minutes to remove air.
- 3) When bleeding is completed removing air inside pump head, connect the discharge hose to its normal piping.
- 4) Confirm no liquid leaks through any parts.

1-2. Adjustment of discharge capacity

Adjustment of discharge capacity can be done by stroke rate adjustment or by stroke length adjustment but basically it is done by adjusting stroke rate. Adjustment by stroke length is auxiliary way to cover the range which is not obtained by stroke rate adjustment.

Precaution for stroke rate adjustment

- 1) When pumping gaseous liquid such as sodium hypochlorite (NaOCl) and hydrazine solution ($\text{N}_2\text{H}_2\text{O}_2$), stroke length must be 100% or near adjusting stroke rate. Discharge capacity may be reduced when stroke length is short.
- 2) When back pressure at discharge side is high, set stroke length to 100% or so adjusting capacity by stroke rate.
- 3) In case the discharge capacity per shot greatly influences the reaction in neutralization or titration application, adjust to short stroke length to reduce capacity per shot and adjust by stroke rate.

Operation

1) Procedure to adjust discharge capacity

Suitable stroke length and stroke rate are decided considering pump operating condition and liquid characteristics etc. Following procedure is recommended.

- a. Set stroke length at 100% and roughly adjust discharge capacity by stroke rate adjustment.
- b. Measure discharged volume.
- c. If measured volume is less than required volume then increase stroke rate to measure again discharged volume.
- d. Do fine adjustment of discharge capacity by adjusting stroke length.
- e. Measure again the discharged volume to confirm the required volume is obtained.

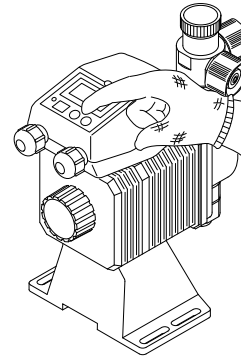
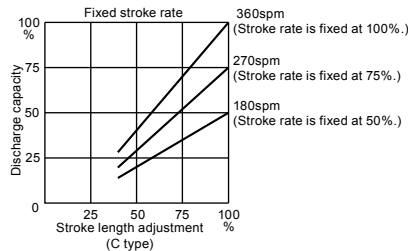
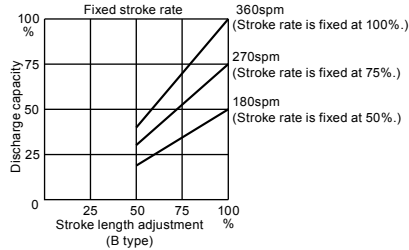

- ## 2) Adjustment of stroke rate
- Setting of stroke rate is done by UP and DOWN keys. Stroke rate per minute of plunger is controlled in the range of 1 to 360 spm.

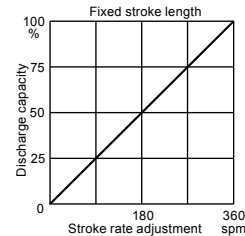

Operation

Caution

Never turn stroke length adjusting knob while pump stops.

3) Stroke length adjustment

Stroke length is adjusted by changing the returning distance of plunger.

a. Turn on power and adjust discharge capacity by stroke length adjusting knob while pump is running.

b. Figure on right shows the relation between discharge capacity and stroke length.

Discharge capacity shows by percent (Discharge capacity shown on nameplate is 100%).

- Stroke length can be adjusted from 0 to 100% but actually adjust it in the range of 50 to 100%.

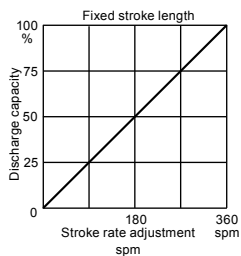
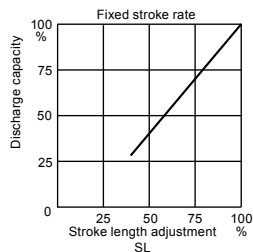
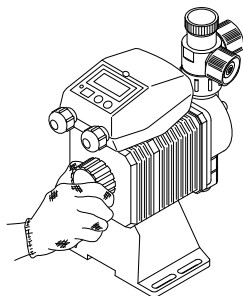

1-3. Precaution when pump is stopped

- In case pump is stopped for a long time (more than one month), operate pump with clean water for 30 minutes to clean wet-end of pump and piping.
- In case start pump again after a long time stoppage, clean valve set if pump does not suck up liquid when pump started. Remove adhered matters if you find them. Remove air if it remains in pump head and re-adjust discharge capacity. (Refer to pages 21 to 23.)
- To stop pump, stop it by key operation before turning off power. Power must be turned off three seconds or after pump is stopped. If power is turned off within three seconds, the key operation of pump stoppage may not be put in memory. In this case pump operates when power is turned on again and liquid is discharged.

Operation

2. Operation of controller

Pump control can be done by operating control unit. Read this chapter thoroughly to correctly operate pump in each operating mode.

The figure on right shows the operation diagram of control unit.

2-1. Control unit operation diagram

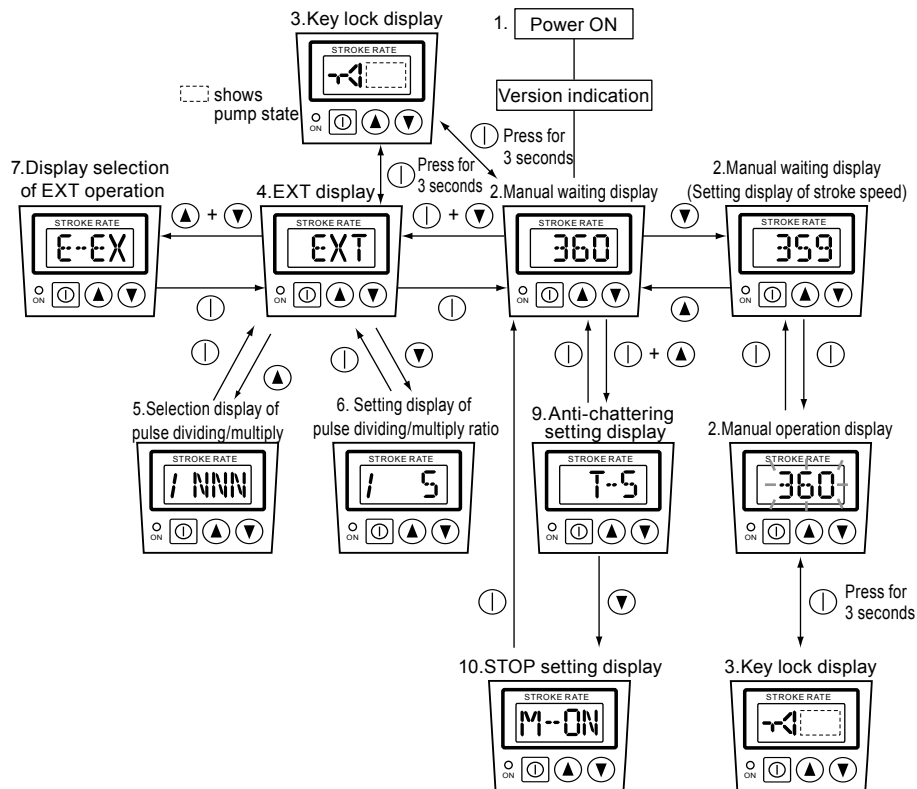

Operation

- 1) When the pump is powered for the first time, built-in program version is shown and then manual waiting mode appears. When pump is powered on and after the second time, pump starts with the status of when pump was turned off last time.
- 2) In manual waiting mode, push start/stop key (1) to start pump. If the key is pushed again, pump stops and moves to manual waiting mode.
- 3) When pressing (1) key for 3 seconds in manual waiting or EXT waiting mode or during manual operation, Key lock function can be active. In this state all the key operations are ineffective. Release the key lock function by pressing (1) key for 3 seconds again.
- 4) EXT mode is to operate pump by external signal.
In manual waiting mode, push (1) key as pressing (1) key to move to EXT mode. To stop pump, push (1) key to move to manual waiting mode.
- 5) To select pulse dividing or pulse multiply, push (1) key in EXT mode to move to the selection display of pulse dividing/pulse multiply.
- 6) To change the pulse dividing/pulse multiply ratio, Push (1) key in EXT mode to move to the setting display of pulse dividing/pulse multiply ratio.
- 7) To display spm indication of EXT operation, push (1) key while pushing (1) key in EXT mode to move to the display selection mode of EXT operation.
- 8) Setting of anti-chattering and STOP function are used in order to change the factory setting value.

- 9) To change the setting of anti-chattering, push (1) key as pressing (1) key to move to anti-chattering setting display. Push (1) key to set and push (1) key to confirm it and return to manual waiting mode.
- 10) To change STOP setting, first push (1) key as pressing (1) key in manual waiting mode to move to anti-chattering setting display. And then push (1) key once to move to STOP setting display. Push (1) key to select M-ON or M-OFF and push (1) key to confirm it and move to manual waiting mode.

For details, refer to Control unit setting/operation procedure.

2-2. Parameter

Mode	Parameter	Factory set	Set range	Step
Manual	Stroke rate (spm) (Note 1)	360	1 ~ 360	1 (Note 2)
	Anti-chattering (Note 3)	T-5	T-5/T-10/T-50	—
	STOP (Note 4)	M-OFF	M-OFF/M-ON	—
EXT	Selection of pulse dividing/multiply	/NNN	/NNN, XNNN	—
	Dividing ratio	1	1-999	1 (Note 2)
	Multiply ratio	1	1-999	1 (Note 2)
	Display selection mode	EX	EX/SP	—

- Note 1. This value is used as the upper limit stroke rate of EXT mode as well.
2. One push changes one stroke. When keeping up or down key pressed, figure changes continuously.
 3. The larger the value is, the stronger against disruption of input pulse it becomes, however, it gets harder for pump to detect pulses if ON time gets shorter. The value is approx. time (msec) for pump to detect pulse. Set the ON time of input pulse larger than chattering value.
 4. If M-ON is selected, pump starts operation upon returning to manual waiting if STOP signal is inputted. Pay attention each time of changing setting.

Operation

2-3. Setting and operation of control unit

2-3-1. Manual operation

1) Turn on power

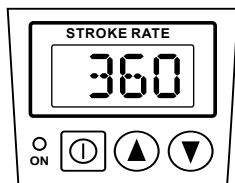

When power is turned on for the first time, program version is shown briefly and manual waiting mode appears. On and after the second time pump is turned on, display shows the mode of when power was turned off last time.



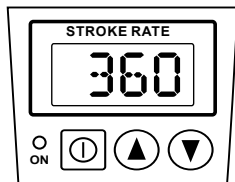



2) Go to manual mode

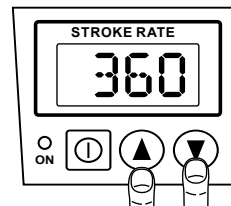

In case stroke rate (1 ~ 360) is not shown on display, move to manual mode with key operation. Push  key when EXT is shown on display. STOP or -STOP indication means STOP function is active. Release STOP function. Refer to page 34 to release STOP function.



3) Set stroke rate

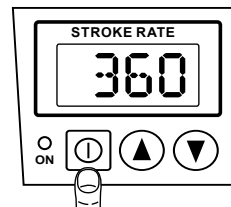

Change stroke rate shown on display by  or  key. If either  or  key is pushed continuously for more than 3 seconds, stroke rate changes quickly. If the key is continuously pressed to change stroke rate, it stops once at figure 1 or 360. And it skips from 360 to 1 by releasing the key and then push  key again, or it skips from 1 to 360 by pushing  key.

4) Start/stop of pump



Push  key once to start pump and then ON lamp and spm indication blink. Push  key again to stop pump and ON lamp lights. (When stroke rate is slow, ON lamp blinks longer.)

Operation

2-3-2. EXT operation

1) Turn on power

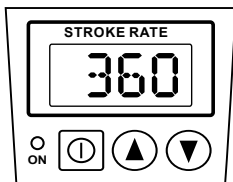

When pump is turned on for the first time, program version is shown briefly and then manual waiting mode appears. On and after the second times, EXT is shown on display if power was turned off last time while pump was in EXT mode.

In case STOP or -STOP is shown, release STOP function because STOP function is active. Refer to page 35 to release STOP function.

2) Set upper limit stroke rate of EXT

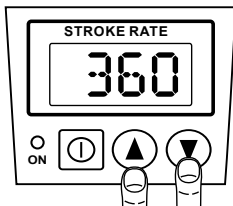

If pump is in manual mode, stop pump and set stroke rate. If pump is in EXT operation mode, push ⏻ key to move to manual waiting mode and set stroke rate.

3) Set EXT operation mode

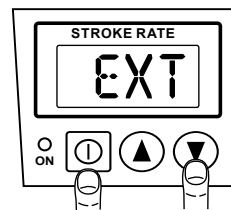

In manual waiting mode push ⏻ key as pressing ⏻ key to move to EXT mode. As soon as pump is in EXT operation mode, pump runs synchronously with EXT input.

4) Return to manual mode

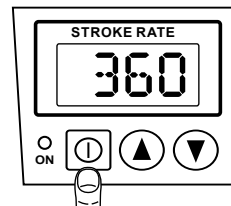

Push ⏻ key once to return to manual waiting mode. Stroke rate appears on display.

Caution

When pump is in EXT operation mode, the maximum number of strokes is equal to the number of strokes displayed in manual operation mode.

For example: When the number of strokes displayed in manual operation mode is 200 spm, the maximum number of strokes in EXT mode is 200 spm and pump operates at 200 spm or below even if pulse signals come to operate pump at 360 spm.

Operation

2-3-3. Key lock function

1) Keypad lock active modes.

Manual waiting mode

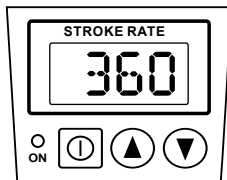

or

During manual operation

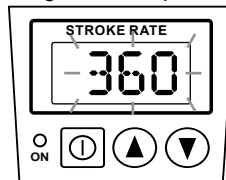

EXT mode

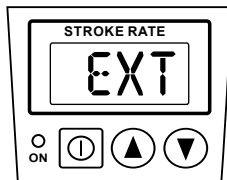

or

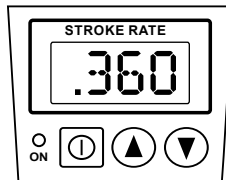

Display one of those modes for locking keypads operation.

2) To have Key lock function active.

During manual operation

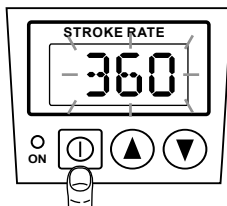

Press  key for 3 seconds when one of the above modes for keypad lock is displayed.

During manual operation or EXT mode.

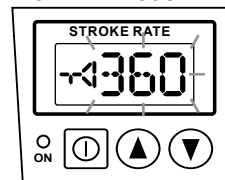

Manual waiting mode

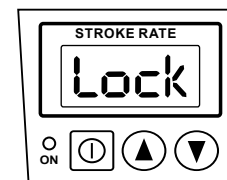

A key mark is indicated during manual operation or EXT mode and keypad operations become ineffective. Lock indication is displayed in manual waiting mode.

3) To release Key lock function.

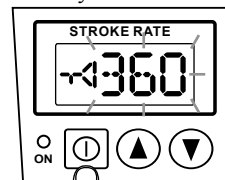

During manual operation with keypad locked

Press  key for 3 seconds when key pad is locked. Key mark disappears and keypad operations become effective.

Caution

All the keypad operations are ineffective when the keypads are locked. Turn off main power source if it is necessary to stop the pump urgently. When turning on power again, the pump restarts with the keypads locked.

And pressing  key for 3 seconds when pumping by stop signals also have the key lock function active, however; the indication is STOP or -STOP. If STOP function is released, the indication changes into that of key lock function.

Operation

2-3-4. Selection of pulse dividing/pulse multiply

1) Turn on power

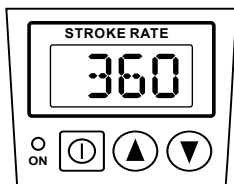

When power is turned on for the first time, program version is shown briefly and manual waiting mode appears. On and after the second time pump is turned on, pump restarts with EXT operation mode and EXT indication appears on the display if the pump was in EXT operation mode when turning off power last time. If STOP or -STOP indication is displayed, STOP function is active. First, release STOP function. Refer to page 35 for how to release STOP function.

2) Move to EXT mode

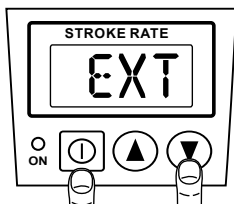

Push $\text{\textcircled{1}}$ key as pressing $\text{\textcircled{1}}$ key in manual waiting mode to move to EXT mode. Do not input any signals at this phase.

3) Move to the selection display of pulse dividing/pulse multiply

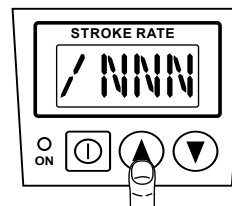

Push \blacktriangle key to move to the selection display of pulse dividing/pulse multiply.

4) Select pulse dividing or pulse multiply.

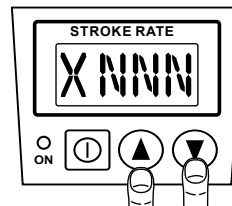

Push \blacktriangle or \blacktriangledown key to select pulse dividing or pulse multiply in the selection display.

Operation

5) Return to EXT mode.

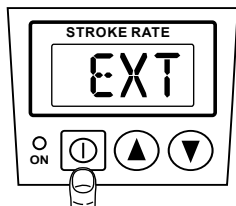

Push  key to move to EXT mode.

2-3-5. Setting of dividing ratio and multiply ratio

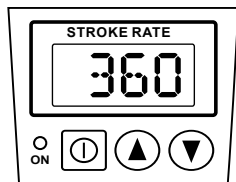

1) Turn on power

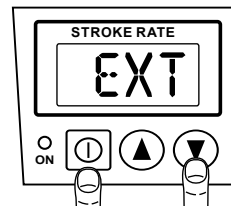

When power is turned on for the first time, program version is shown briefly and manual waiting mode appears. On and after the second time pump is turned on, pump restarts with EXT operation mode and EXT indication appears on the display if the pump was in EXT operation mode when turning off power last time. If STOP or -STOP indication is displayed, STOP function is active. First, release STOP function. Refer to P.35 for how to release STOP function.

2) Move to EXT mode



Push  key as pressing  key in manual waiting mode to move to EXT mode. Do not input any signals at this phase.

3) Move to the setting display of dividing ratio and multiply ratio.

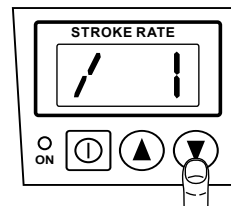



Push  key once to move to the setting display of dividing ratio and multiply ratio.

Operation

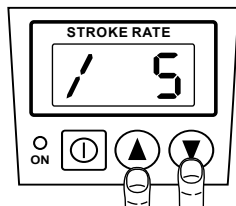
4) Set the dividing ratio or multiply ratio



Use  or  key to set the dividing ratio or multiply ratio in the setting display.

5) Return to EXT mode

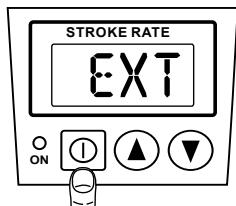

Push  key to return to EXT mode.

2-3-6. Display selection mode of EXT operation

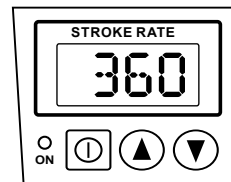

1) Turn on power

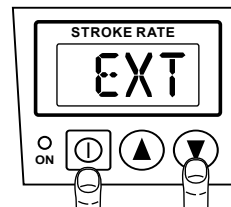

When power is turned on for the first time, program version is shown briefly and manual waiting mode appears. On and after the second time pump is turned on, pump restarts with EXT operation mode and EXT indication appears on the display if the pump was in EXT operation mode when turning off power last time. If STOP or -STOP indication is displayed, STOP function is active. First, release STOP function. Refer to P.35 for how to release STOP function.

2) Move to EXT mode





Push  key as pressing  in manual waiting mode to move to EXT mode. Do not input any signals at this phase.

Operation

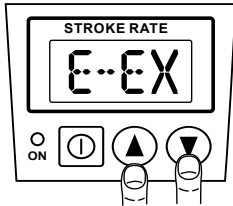

3) Move to the display selection mode of EXT operation



Push  key while pressing  key to move to the display selection mode of EXT operation.

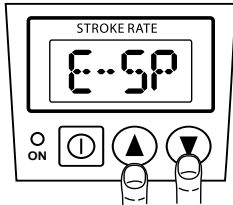

4) Select EXT indication or spm indication

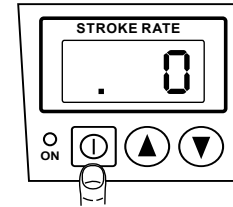

Use  or  key to select EXT indication or spm indication in the display selection mode of EXT operation.

5) Return to EXT mode



Push  key to return to EXT mode. The above display shows  when spm indication is selected.

Caution
The spm indication on the display via the display selection reflects the actual pump rotation speed. It does not reflect the speed of incoming external signals.

Operation

2-3-7. Setting of anti-chattering value

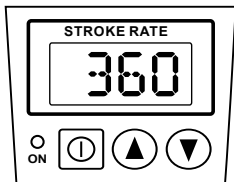

1) Go to manual waiting mode



If pump is EXT mode, push  key. If STOP or -STOP is shown, release STOP function because STOP function is active. Refer to page 35 to release STOP function.

2) Set anti-chattering value



In manual waiting mode, push  key as pressing  key in order to indicate T-5 (factory setting) on display.

3) Change anti-chattering value

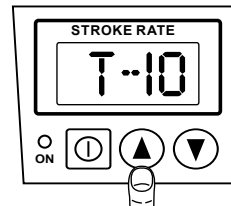

Push  key to change T-5, T-10 or T-50.

4) Fix the setting and return to manual waiting mode.

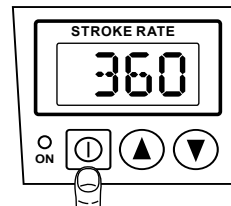



After the setting of anti-chattering value, push  key to confirm the setting and return to manual waiting mode. When pump is used together with pump controller 50 series, set anti-chattering to T-5. Pump may not operate if it is set to T-10 or T-50.

Operation

2-3-8. Setting of STOP function

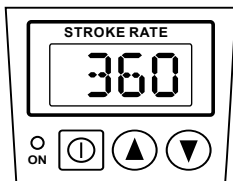

1) Go to manual waiting mode

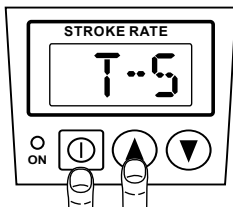

If pump is in EXT mode, push  key. STOP or -STOP indication means STOP function is active. Release STOP function. Refer to page 35 to release STOP function.

2) Go to anti-chattering setting display



In manual waiting mode, push  and  keys simultaneously to show T-5 (factory setting) on display.

3) Go to STOP setting display

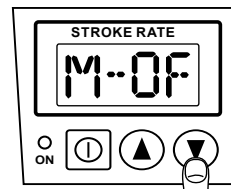

Push  key once to show either M-OF (factory setting) or M-ON on display.

4) Change STOP setting

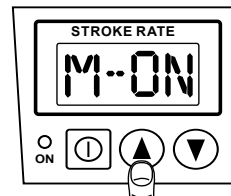

Push  key to select M-OF or M-ON.

5) Fix STOP setting and return to manual waiting mode.

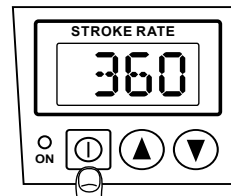

Push  key to fix setting and return to manual waiting mode.

Caution
M-ON: Pump starts to run when STOP signals are inputted.
M-OFF: Pump stops running when STOP signals are inputted.

Operation

2-3-9. Setting of STOP function

1) Move to the waiting mode of STOP function.

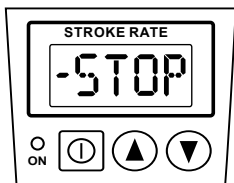

If display shows "STOP", push key to stop pump operation. When -STOP indication appears, push ▲ key while pressing ⓪ key to move to anch-chattering setting.

2) Move to anti-chattering setting display.

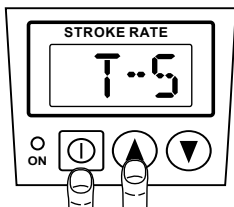

When -STOP indication appears, push ▲ key while pressing ⓪ key. Display shows "T-5" "T-10" or "T-50".

3) Move to STOP setting display.

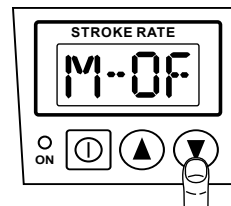

Push ▼ key once. Display shows "M-OFF" or "M-ON". STOP function can be released by changing this setting.

4) Change current STOP setting.

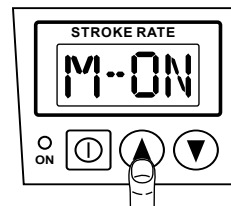

Push ▲ to select "M-OFF" or "M-ON".

5) Confirm new STOP setting and return to manual mode

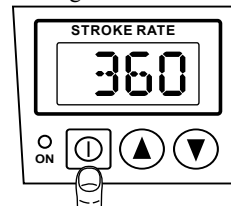

Push key to confirm new setting. Pump enter to waiting mode and STOP function is released.

Maintenance

Maintenance, inspection, disassembling and assembling should be done according to this instruction manual. Do not handle the pump beyond the instruction shown on this manual.

Warning

• Wear protector

You may be injured by chemical or toxic liquid if they are splashed or you touch them. Wear protector such as protective mask, safety globe or so when the works are done.



• Turn off power

You may be electrically shocked if you do the works while power is turned on. When you do the works be sure to turn off power of pump or other equipment. When you stop pump, it should be stopped by key operation before you turn off power. Power must be turned off at least three seconds after pump is stopped by key operation. If power is turned off within three seconds, pump stopping operation may not be put in memory. If this happens, pump starts when power is turned on again and chemical may be discharged.



1. Troubleshooting

Trouble	Cause	Troubleshooting
Pump does not start.	<ul style="list-style-type: none"> ● Faulty wiring or disconnection in wiring ● Lowered voltage ● Electronic circuit of control unit is damaged. 	<ul style="list-style-type: none"> ○ Correct wiring. ○ Trace cause and raise voltage to specified level. ○ Replace the whole unit. (Substrate part cannot be repaired.)
Liquid suction cannot be done.	<ul style="list-style-type: none"> ● Air suction in suction piping ● Valve gasket is not installed. ● Valve set assembling direction is wrong. ● Pump is air-locked. ● Pump stroke length is too short. ● Suction-side/discharge-side valve is clogged with foreign matter. ● Adhesion of valve onto valve seat 	<ul style="list-style-type: none"> ○ Set piping normally. ○ Install valve gasket. ○ Reassemble valve set. ○ Carry out air elimination. ○ Drive pump with stroke length set at 100%. Then, reset stroke length. ○ Disassemble, inspect, and clean. ○ Disassemble, inspect, and clean.
Discharge amount fluctuates.	<ul style="list-style-type: none"> ● Suction-side/discharge-side valve is clogged with foreign matter. ● Air is trapped in pump. ● Overfeeding ● <u>Diaphragm is damaged.</u> 	<ul style="list-style-type: none"> ○ Disassemble, inspect, and clean. ○ Carry out air elimination. ○ Install check valve. ○ <u>Replace diaphragm.</u>
Liquid leaks.	<ul style="list-style-type: none"> ● Valve or connecting port is not tightly closed. ● Pump head is not tightly closed. ● Diaphragm is damaged. ● O ring and valve gasket are not installed. 	<ul style="list-style-type: none"> ○ Tighten section. ○ Tighten pump head. Torque: 2.16 N·m (B10, B15, B20, C15, C20) 2.55 N·m (B30, C30, C35) ○ Replace diaphragm. ○ Install O ring and valve gasket.

Maintenance

2. Maintenance and inspection

Pay attention to the following points during pump operation. Stop pump immediately if you find abnormality and take measures according to the item "Troubleshooting". When wear parts come to the life time, replace them by new ones. (Refer to the item "Wear parts".

No.	Check Point	Description	How to Check
1	Does pump lift liquid normally?	<ul style="list-style-type: none"> Is liquid normally fed? Is suction pressure/discharge pressure at normal level? Has liquid undergone quality change, crystallization, or solidification? 	<ul style="list-style-type: none"> By flow meter or visual inspection Check nameplate. By visual inspection
2	Abnormal noise or vibration?	<ul style="list-style-type: none"> Abnormal noise or vibration may result from abnormal functioning of pump. 	<ul style="list-style-type: none"> By visual and audio inspection
3	Is there liquid leakage or air suction at any joint on pump or piping?	<ul style="list-style-type: none"> Tighten joint where leakage has occurred. Excessive air bubbles in discharged liquid mean air suction has been caused in system. Examine the piping and tighten joint which leaks. 	<ul style="list-style-type: none"> By visual inspection







Check to see periodically if pump head mounting bolts are not loosened, and tighten them by diagonal order if necessary. Pump head mounting bolts may be loosened during pump operation.

Tightening torque of pump head mounting screw

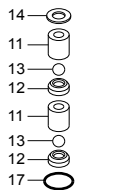
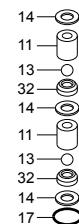
Model	Torque	Remarks
EHN-B10 15 20	2.16N m	M4 hex. socket head screw
EHN-B30	2.55N m	M4 hex. socket head screw
EHN-C15 20	2.16N m	M4 hex. socket head screw
EHN-C30	2.55N m	M4 hex. socket head screw
EHN-C35	2.55N m	M5 hex. socket head screw

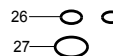
3. Wear parts

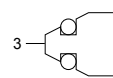
If pump is to be used for a long period, wear parts should be replaced in proper period. It is recommended that following parts are always ready for the replacement.

	Parts		Q'ty	Time to be replaced
	VC, VH, PC, PH	PP		
Pump head	Valve set 		2 sets	8000 hours
	Diaphragm 		1	
	O ring 		-	
Check valve	Check valve poppet (with O ring) 		-	1
	Check valve spring 		-	1

Note: Durability of wear parts depend on pumped liquid, temperature and pressure.

Time to be replaced mentioned as above is the estimation obtained by continuous pumping of clean water at ambient temperature.

Maintenance

4. Disassembling and assembling

Warning

- **Wear protector**

You may be injured by chemical or toxic liquid if they are splashed or you touch them. Wear protector such as protective mask, safety globe or so when the works are done.



Wear protective gear

- **Turn off power**

You may be electrically shocked if you do the works while power is turned on. When you do the works be sure to turn off power of pump or other equipment. When you stop pump, it should be stopped by key operation before you turn off power. Power must be turned off at least three seconds after pump is stopped by key operation. If power is turned off within three seconds, pump stopping operation may not be put in memory. If this happens, pump starts when power is turned on again and chemical may be discharged.



- **Release the pressure inside pump and discharge hose prior to loosening the piping connections or dismantlement of pump. Dismantlement with pressure inside pump could lead to liquid eruption.**



- **Pay attention not to touch residual liquid when dismantling pump.**



Caution

Method to release pressure:

- 1) Stop pump
- 2) Turn bleed adjusting screw to left by two turns to fully open bleed port.
- 3) Confirm liquid goes out from bleed port and pressure was released.

Caution : If liquid does not go out, the pressure may be kept inside.

In this case operate pump in this condition to discharge liquid bleed port and confirm the pressure is released.

EHN-30-35 types (excluding PP type) are not equipped with bleed valve. For these types install an bleed valve at discharge piping to release valve.

Before works

- When pump is disassembled, pay attention to the liquid which may remain inside pump.
- Wash wet-end of pump head.

Works

- When pump head is disassembled, replace diaphragm, O ring, valve gasket and valve set by new ones.

Caution

- Pump is not water-proof construction.
- If liquid is splashed on pump (driving unit, control unit, pump head), they may be failed and accident may occur. Do not splash liquid on them. If splashed, wipe them off with cloth.

Maintenance

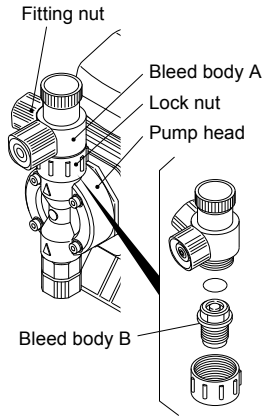

4-1. Valve assembly

■ Disassembly of discharge valve

● EHN- ()10, 15 & 20

- 1) Loosen fitting nut and remove suction hose, discharge hose and bleed hose.
- 2) Turn a lock nut of bleed unit to left (seen from top) to remove bleed body A.
- 3) Remove bleed body B with spanner.
- 4) Take valve set out with tweezers.

● EHN- ()30 & 35

Loosen connection port with spanner to remove it and take valve set out with tweezers.

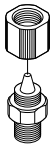

Connection port

Maintenance

■ Disassembly of suction valve

- 1) Loosen fitting nut to remove suction hose and bleed hose.
- 2) Loosen connection port with spanner.
- 3) Remove connection port and take valve set out.

Caution
Pay attention not to drop valve set.

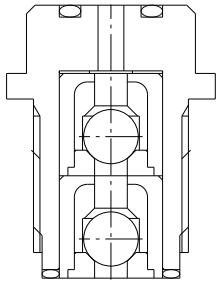

Arrangement of suction valve

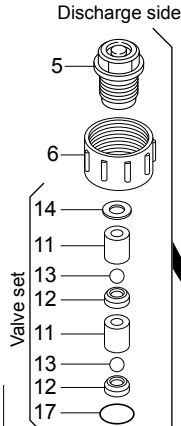

Discharge side

Valve set

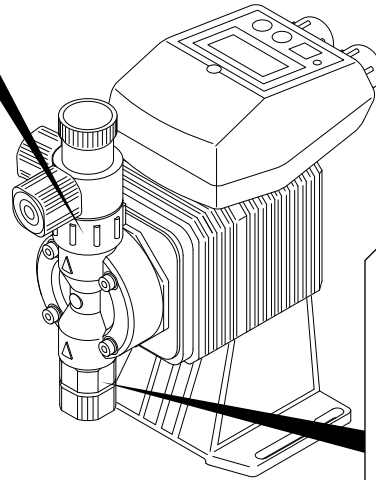

Suction side

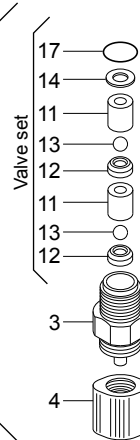

Valve set

■ Assembly

Assembly is done in reverse order to disassembly. Pay attention to following.

- Pay attention to arrangement of valve set. Wrong arrangement and direction will cause failed pumping (liquid leakage, decreased discharge capacity).
- Be sure to mount O ring and gasket.

- 1) Mount discharge side valve set
Put valve set in pump head and put bleed body B (5) through lock nut (6) and tighten it.
- 2) Mount suction side valve set
Put valve set in connection port (3) and screw the connection port into pump head by hand and then re-tighten it by 1/4 turns with spanner.

Maintenance

4-2. Bleed assembly

- VC, VH, PC, PH types

Loosen lock nut with spanner and bleed valve can turn by 180 degree to choose hose connection direction optionally. Once direction is decided, tighten lock nut to fix it. To tighten lock nut, hold bleed body A by hand and tighten lock nut by hand to clockwise seen from top, and then turn it with spanner by 1/4 turns.

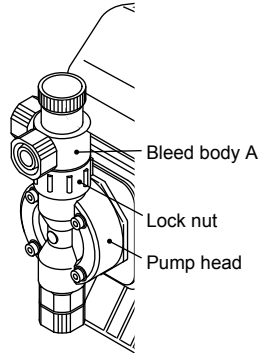

Warning

Pay attention not to lose diaphragm spacer and to apply correct number of diaphragm spacer. 0 to several pieces of diaphragm spacers are put between retainer and plunger to adjust position of diaphragm. Number of spacers mounted depends on pump model and there is the model on which no spacer is mounted.

4-3. Diaphragm

- Disassembly of diaphragm

- 1) Remove suction hose, discharge hose and bleed hose.
- 2) Remove pump head with hex. wrench.
- 3) Turn diaphragm to remove it from plunger (pump shaft).

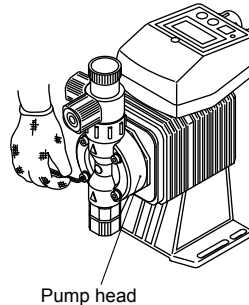

Maintenance

■ Assembly of diaphragm

- 1) Operate pump to set stroke length at 0% and stop it.
- 2) Put retainer and diaphragm spacer (if used) on the threaded part of new diaphragm.

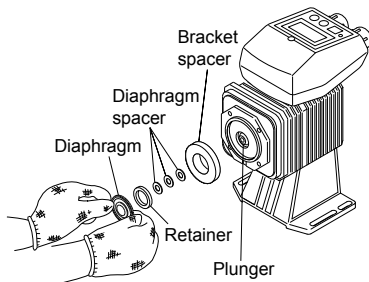

Caution

Round edge of retainer should be directed to diaphragm side.
Do not remove a bracket spacer. If removed, mating projected and recessed part of bracket and bracket spacer insert it to the bottom.

- 3) Screw diaphragm into plunger.
- 4) Operate pump to set stroke length at 100% and stop it.
- 5) Tighten bolts evenly (diagonally) to mount pump head.

Tightening torque

Model	Torque	Remarks
EHN-B10 15 20	2.16N m	M4 Hex. socket head bolt
EHN-B30	2.55N m	M4 Hex. socket head bolt
EHN-C15 20	2.16N m	M4 Hex. socket head bolt
EHN-C30	2.55N m	M4 Hex. socket head bolt
EHN-C35	2.55N m	M5 Hex. socket head bolt

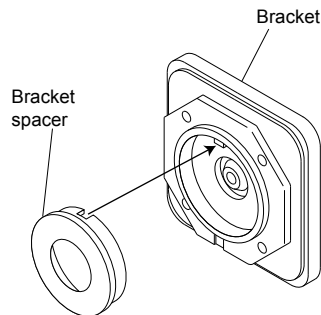

Exploded view (VC, VH, PC, PH, FC types)

Parts are completely disassembled to show them but the extent of disassembling is limited to the instruction shown on Maintenance section.

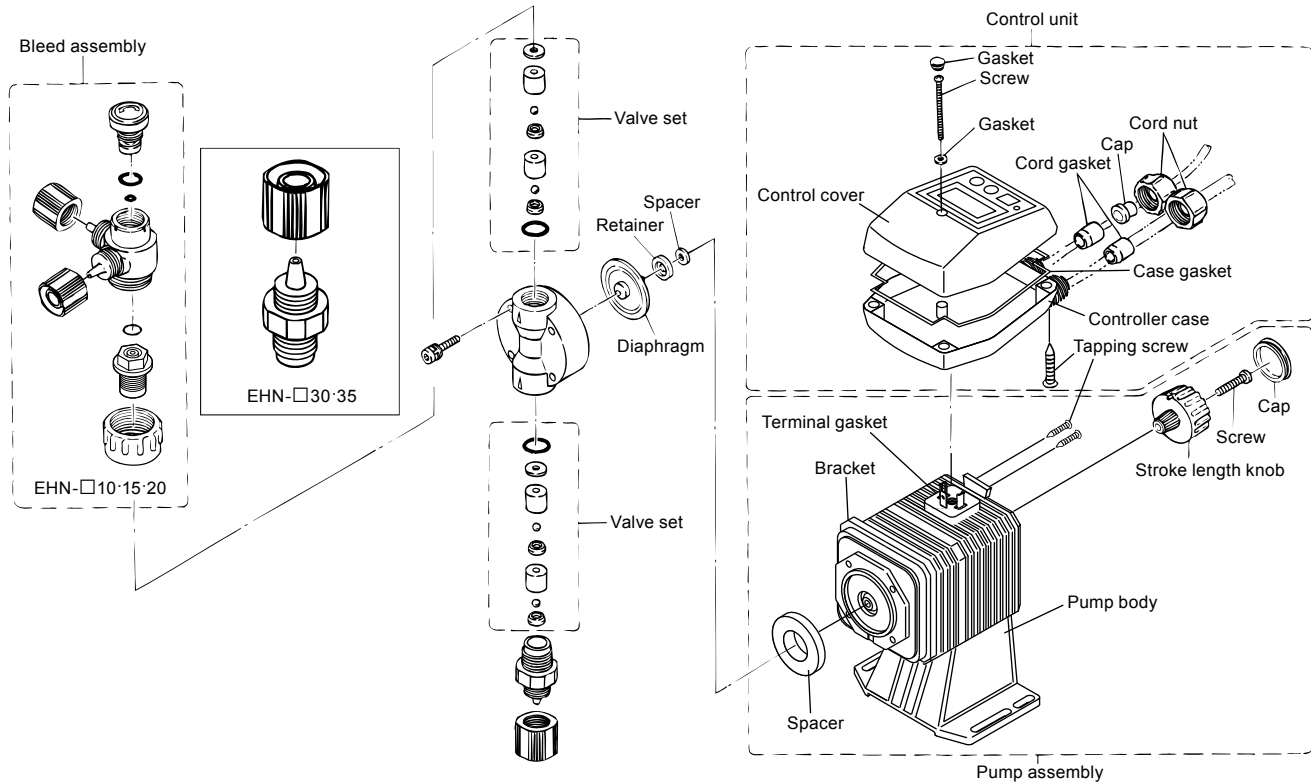

Exploded view (VC, VH, PC, PH types)

■ Pump head

● EHN-B10 B15 B20, C15 C20 (VC VH PC PH) ● EHN-B30, C30 C35 (VC VH PC PH)

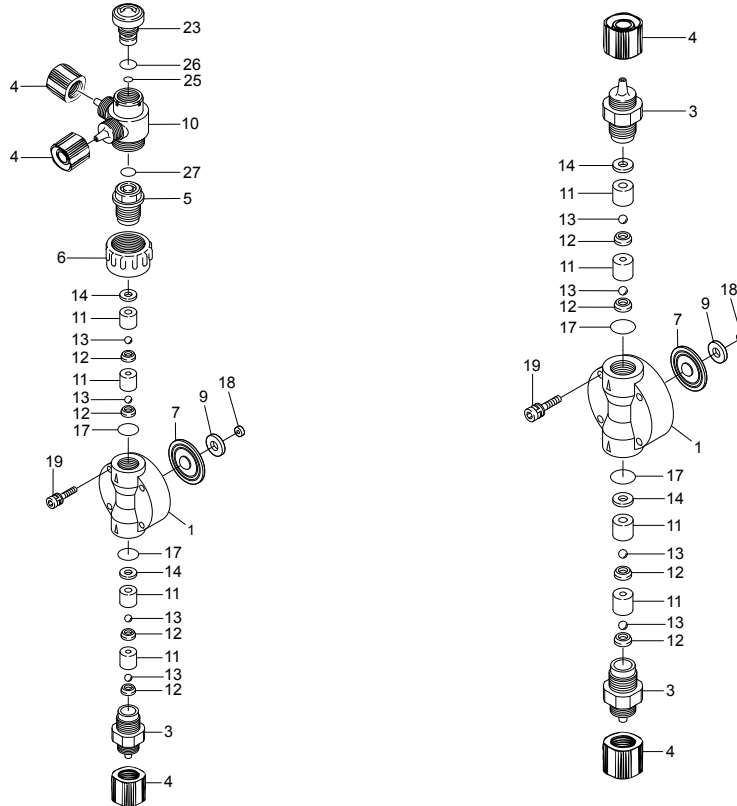

No.	Parts name	Q'ty
1	Pump head	1
3	Connection port	1(2)
4	Fitting nut	3(2)
5	Bleed body B	1(none)
6	Lock nut	1(none)
7	Diaphragm	1
9	Retainer	1
10	Bleed body A	1(none)
11	Valve guide	4
12	Valve seat	4
13	Valve	4
14	Valve gasket	2
17	O ring	2
18	Diaphragm spacer	
19	Hex. socket head bolt (with PW, SW)	4
23	Bleed adjusting screw	1(none)
25	O ring	1(none)
26	O ring	1(none)
27	O ring	1(none)

Figures in () are for EHN-B30, C30 and C35.

Exploded view (PP type)

• EHN-PP

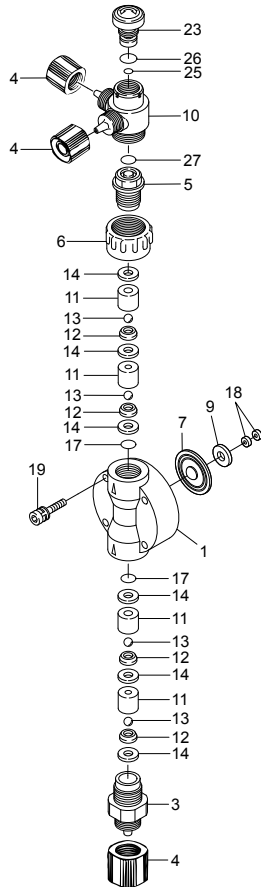

No.	Parts name	Q'ty
1	Pump head	1
3	Connection port	2
4	Fitting nut	3(2)
5	Bleed body B	1(none)
6	Lock nut	1(none)
7	Diaphragm	1
9	Retainer	1
10	Bleed body A	1(none)
11	Valve guide	4
12	Valve seat	4
13	Valve	4
14	Valve gasket	6
17	O ring	2
18	Diaphragm spacer	
19	Hex. socket head bolt	4
23	Bleed adjusting screw	1(none)
25	O ring	1(none)
26	O ring	1(none)
27	O ring	1(none)

Figures in () are for EHN-B30, C30 and C35.

Exploded view

- Check valve (VC, VH, PC, PH)

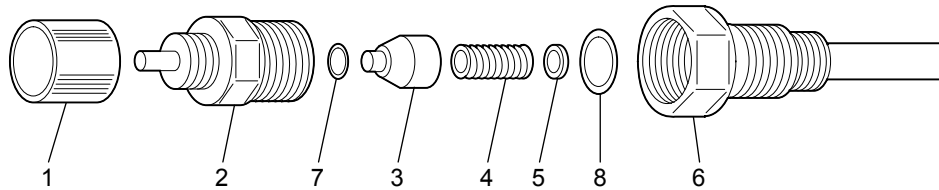

No.	Parts name	Q'ty
1	Fitting nut	1
2	Valve case	1
3	Poppet	1
4	Spring	1
5	Spacer	1
6	Valve fitting A	1
7	O ring	1
8	O ring	1

Outline dimension

- EHN-B10, B15, B20 (VC, VH, PC, PH & PP)

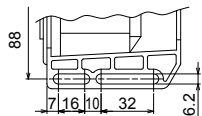
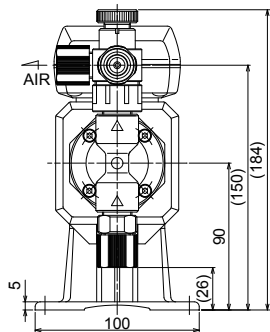
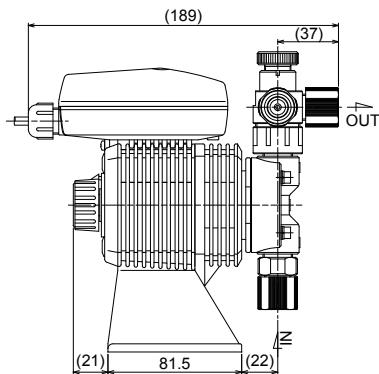

- EHN-B30 (VC, VH, PC, PH)

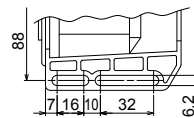
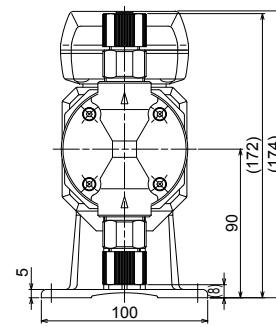
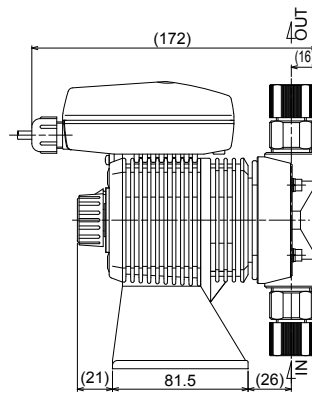

Outline dimension

- EHN-C15, C20 (VC, VH, PC, PH & PP)

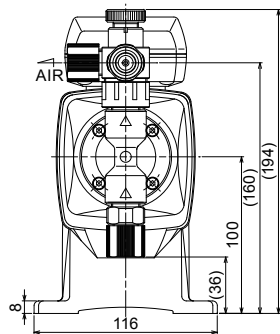
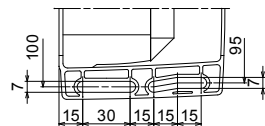
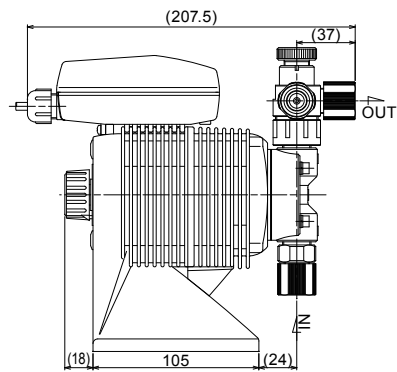

- EHN-C30, C35 (VC, VH, PC, PH, PC)

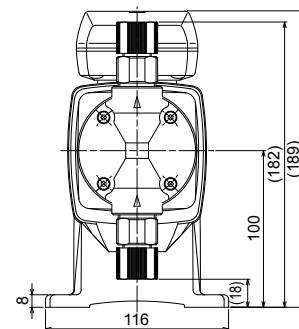
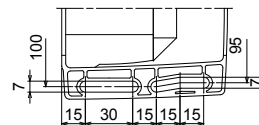
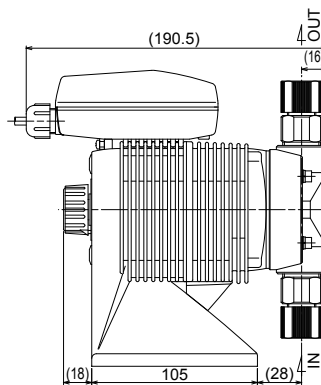



IWAKI CO.,LTD. 6-6 Kanda-Sudacho 2-chome Chiyoda-ku Tokyo 101-8558 Japan

TEL: (81)3 3254 2935 FAX: 3 3252 8892 (<http://www.iwakipumps.jp>)

() Country codes

U.S.A. : IWAKI America Incorporated	TEL : (1)508 429 1440	FAX : 508 429 1386	Germany : IWAKI EUROPE GmbH	TEL : (49)2154 9254 0	FAX : 2154 1028
Australia : IWAKI Pumps Australia Pty. Ltd.	TEL : (61)2 9899 2411	FAX : 2 9899 2421	Italy : IWAKI Italia S.R.L.	TEL : (39)02 990 3931	FAX : 02 990 42888
Singapore : IWAKI Singapore Pte. Ltd.	TEL : (65)6316 2028	FAX : 6316 3221	Denmark : IWAKI Nordic A/S	TEL : (45)48 24 2345	FAX : 48 24 2346
Indonesia : IWAKI Singapore (Indonesia Branch)	TEL : (62)21 690 6606	FAX : 21 690 6612	Sweden : IWAKI Sverige AB	TEL : (46)8 511 72900	FAX : 8 511 72922
Malaysia : IWAKIm Sdn. Bhd.	TEL : (60)3 7803 8807	FAX : 3 7803 4800	Finland : IWAKI Suomi Oy	TEL : (358)9 2742714	FAX : 9 2742715
Taiwan : IWAKI Pumps Taiwan Co., Ltd.	TEL : (886)2 8227 6900	FAX : 2 8227 6818	Norway : IWAKI Norge AS	TEL : (47)66 81 16 60	FAX : 66 81 16 61
Thailand : IWAKI (Thailand) Co.,Ltd.	TEL : (66)2 322 2471	FAX : 2 322 2477	France : IWAKI France S.A.	TEL : (33)1 69 63 33 70	FAX : 1 64 49 92 73
Hong Kong : IWAKI Pumps Co., Ltd.	TEL : (852)2 607 1168	FAX : 2 607 1000	U.K. : IWAKI PUMPS (UK) LTD.	TEL : (44)1743 231363	FAX : 1743 366507
China : IWAKI Pumps (Guandong) Co., Ltd.	TEL : (86)750 380 9018	FAX : 750 380 9078	Switzerland : IWAKI (Schweiz) AG	TEL : (41)26 674 9300	FAX : 26 674 9302
China : GFTZ IWAKI Engineering & Trading (Guangzhou)	TEL : (86)20 8435 0603	FAX : 20 8435 9181	Austria : IWAKI (Austria) GmbH	TEL : (43)2236 33469	FAX : 2236 33469
China : IWAKI Pumps Co., Ltd. (Beijing)	TEL : (86)10 6442 7713	FAX : 10 6442 7712	Holland : IWAKI Holland B.V.	TEL : (31)297 241121	FAX : 297 273902
China : IWAKI Pumps (Shanghai) Co., Ltd.	TEL : (86)21 6272 7502	FAX : 21 6272 6929	Spain : IWAKI Iberica Pumps, S.A.	TEL : (34)943 630030	FAX : 943 628799
Philippines : IWAKI Chemical Pumps Philippines, Inc.	TEL : (63)2 888 0245	FAX : 2 843 3096	Belgium : IWAKI Belgium n.v.	TEL : (32)1367 0200	FAX : 1367 2030
Korea : IWAKI Korea Co.,Ltd.	TEL : (82)2 3474 0523	FAX : 2 3474 0221			