



IWAKI Magnetic Drive Pump

AMP Series (Asia Edition: English)

Instruction Manual

⚠ Read this manual before use of product

Thank you for selecting an Iwaki AMP Series Magnetic Drive Pump. This instruction manual deals with "*Safety instructions*", "*Outline*", "*Installation*", "*Operation*", and "*Maintenance*" sections. Please read through this manual carefully to ensure the optimum performance, safety and service of your pump.

Contents

Important instructions	1
Safety instructions	2
<i>Outline</i>	
1. Unpacking & Inspection	5
2. Model code.....	6
3. Operating conditions	7
4. Part names.....	8
<i>Installation</i>	
1. Before installation	10
2. Piping	11
3. Wiring	14
4. Protection equipment	14
<i>Operation</i>	
1. Before operation	16
2. Operation	17
3. Shutdown.....	17
<i>Maintenance</i>	
1. Troubleshooting.....	19
2. Maintenance & Inspection	21
3. Disassembly & Assembly	23
4. Spare & Wear parts.....	29



This instruction manual should be kept on hand by the end user for quick reference.

Contact us or your nearest dealer if you have any questions.

Important Instructions

For the Safe and Correct Handling of the Pump

- "Safety Instruction" section deals with important details about handling of the product. Before the use of the pump, read this section carefully for the prevention of personnel injury or loss.
- Observe the instructions accompanied with "WARNING" or "CAUTION" in this manual. These instructions are very important for protecting users from dangerous situations.
- The symbols on this instruction manual have the following meanings:

 WARNING	Nonobservance or misapplication of “Warning” sections could lead to a serious accident which may result in death.
 CAUTION	Nonobservance or misapplication of “Caution” sections could lead to a personal injury or damage to the product.

Types of Symbols



Indicates that “Warning” or “Caution” must be exercised. Inside this triangle, a concrete and practical image provided as a warning or caution message is depicted.



Indicates a prohibited action or procedure. Inside or near this circle, a concrete and practical image of the activity to be avoided is depicted.



Indicates an important action or procedure which must be performed or carried out without fail. Failure to follow the instructions herein can lead to malfunction or damage to the pump.

Safety instructions

WARNING

- **Pay attention to the magnet field**

The magnet drive pump has a pair of strong magnets. The strong magnet field could adversely affect the persons who are assisted by electronic devices such as the pacemaker.



- **Power OFF**

Be sure to turn off the power before starting a maintenance/repair work. Make sure no one turns on the power while working on the pump, otherwise it may result in a serious accident. If your work field is noisy or dark, let other people know about the situation by displaying a notice such as "POWER OFF (Maintenance)" near the power switch.



- **Wear protective clothing**

Always wear protective clothing such as eye protection and protective gloves during pipework or dismantlement of the pump.



- **When lifting the pump**

Chain the pump via eye bolts to lift it up.



- **Do not remodel the pump**

Do not remodel the pump. We are not responsible for a personal injury or pump damage due to any modification.



- **When handling dangerous liquid**

For the transfer of the harmful liquid as mentioned below, be sure to conduct daily inspection and maintenance for the prevention of liquid/gas leakage or other failure.



1. Explosive or flammable liquid
2. Corrosive or stimulus toxic liquid
3. Health hazardous liquid

- **Ventilation**

Poisoning may result when handling a toxic or odorous liquid. Keep good ventilation in your operating site.



Safety instructions

CAUTION

- **Attention to magnetic force**

A pair of strong magnets is mounted in the pump and may cause personal injury. Follow "Disassembly & Assembly" section when dismantling and/or assembling the pump.



- **Do not run pump dry**

Do not run pump dry (Operation without liquid). Friction heat in the dry running causes the pump damage. If the pump is operated with a suction side valve closed, the pump runs dry.



Prohibited

Note that the CF type of high density carbon bearing can run dry within one hour.

- **Restriction on pump operator**

The pump must be handled or operated by a qualified person with a full understanding of the pump.



- **For a specified application only**

Use of the pump in any application other than those clearly specified may result in pump failure or damage.



Prohibited

- **Static electricity**

Take countermeasures to remove the static electricity when low electric conductivity liquids such as ultra-pure water and fluor inactive liquid (e.g. Fluorinert™) are handled. Otherwise, the static electricity may generate in the pump and may cause static discharge.



- **Static electricity**

Always run the pump for air elimination before full operation. Note that hydrogen peroxide and sodium hypochlorite easily generate gas. If the pump runs without full air elimination, the pump is damaged by friction heat.



- **Countermeasure against efflux**

Take a protective measurement against accidental chemical efflux and splash at pump or piping breakage. Also, take an appropriate measurement to prevent accidental outflow from directly soaking into the ground. Otherwise, it leads to personal injury or environmental damage.



- **Pump disposal**

Any used or damaged pump must be disposed of in accordance with local laws and regulations as an incombustible (Consult a licensed industrial waste products disposing company.). Neutralize and flush out chemicals before disposal. Do not incinerate fluororesin parts. Fluororesin emits harmful gas when it is burnt and affects human health and environment.



Outline

<i>1. Unpacking & Inspection</i>	<i>5</i>
<i>2. Model code</i>	<i>6</i>
<i>3. Operating conditions</i>	<i>7</i>
<i>4. Part names</i>	<i>8</i>

Outline

1. Unpacking & Inspection

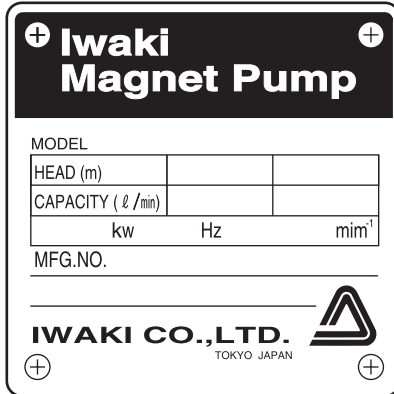

On unpacking the product, check the following points. If you find any problems, contact your nearest dealer.

1. Check the information on nameplate and confirm the product is delivered as per order.
2. Check for transit damage, deformation, and loose bolts.
 - ! Tighten the rear casing support mounting bolts to the specified tightening torque. See "13. Disassembling & Assembling" section for the specified tightening torque.

3. Check if accessories are included.

Bolt for back pull-out:

M12×100mm (2pcs)

Optional accessories (if ordered):

Spare parts and the dry run protector, etc.

Pump unit (Liquid feeding section)
 Not capable of self-priming:
 Before operating the pump, feed liquid through the suction or discharge port.

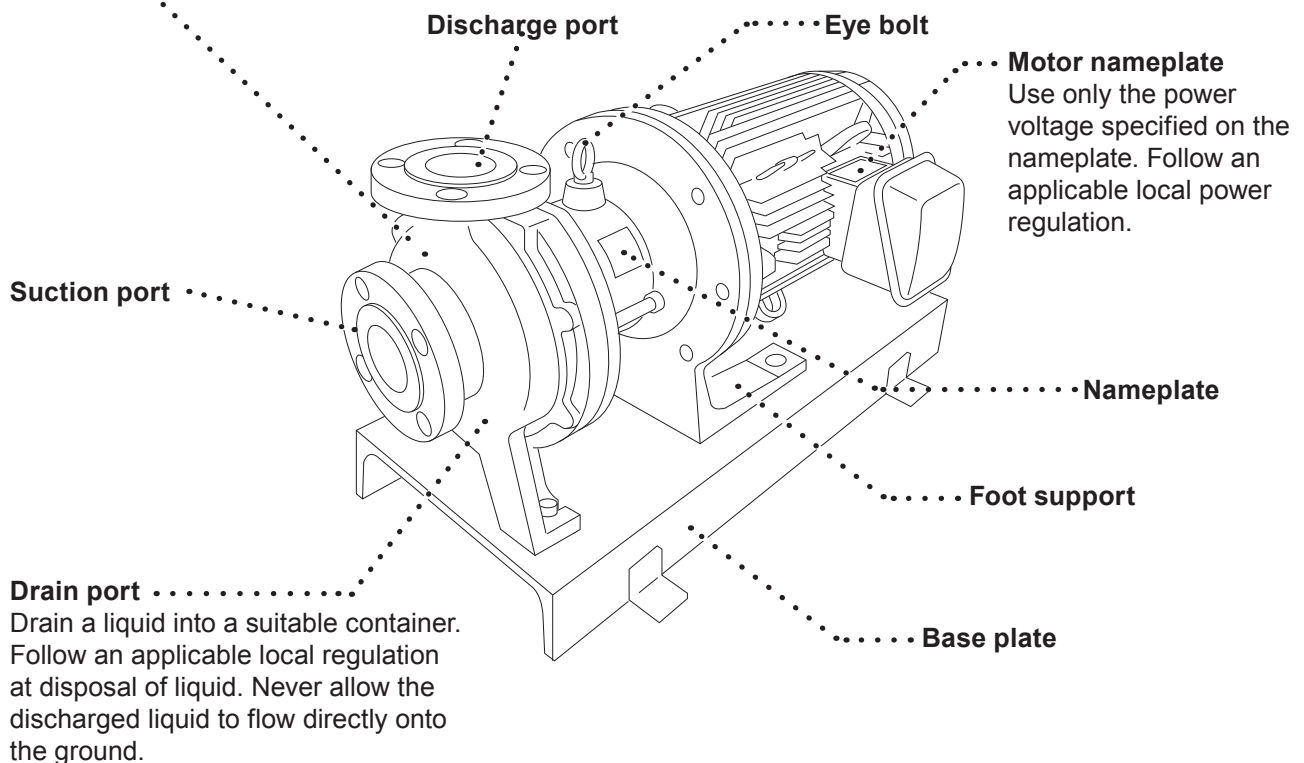

CAUTION

When cleaning the pump, do not wipe the nameplates, labels or the pump body with any solvent.

Outline

2. Model code

AMP40 - 150 1 KK F 075 J - D 2

① ② ③ ④ ⑤ ⑥ ⑦ ⑧ ⑨

① Pump discharge bore:

Suction	×	Discharge
40: 50	×	40
50: 65	×	50

② Nominal impeller diameter: 110 - 165 (mm)

③ Impeller code: 1

④ Bearing/Spindle material: KK: SiC/SiC CF: High density carbon/High purity ceramic

⑤ Motor type: F: Flanged motor

⑥ Motor output: 037: 3.7 kW, 055: 5.5 kW, 075: 7.5 kW

⑦ Flange/Motor standards J: JIS pump flange + JIS motor A: ANSI pump flange + JIS motor

⑧ Drain/Custom product

	Drain	Base plate	Standard or Custom product
A	Without drain	With base plate	Standard
S			Custom product
D	With drain		Standard
X			Custom product
B	Without drain	Without base plate	Standard
Y			Custom product
E	With drain		Standard
Z			Custom product

⑨ Number of motor poles: 2: Two pole motor

NOTE: In this manual, model code is simplified by using pump discharge bore code ① and impeller range code ③.

Outline

3. Operating conditions

1. Permissible pressure

Pump permissible pressure is 1.0MPa. Do not allow the pump discharge pressure to exceed the limit.

2. Slurry liquid

Slurry liquid can not be used except for the KK type of SiC bearing. The KK type can handle slurry in the following conditions:

- Slurry concentration up to 5 wt%
- Slurry hardness up to 80 Hs
- Slurry size up to 50 μm

Contact us for detail before slurry transfer.

NOTE: Not only friction parts but also plastic parts are worn when handling slurry liquid.

Note that periodic pump change is needed.

3. Performance change along with specific gravity and viscosity

Shaft power, discharge capacity and discharge head vary with specific gravity and viscosity. The pump has been made in accordance with the specified operating condition at order phase. If the operating condition has been changed since then, contact us before use of the pump.

4. Influence by liquid temperature

Viscosity, vapour pressure and corrosiveness vary with the temperature change. Pay attention to the change of liquid characteristics.

- Liquid temperature range: 0-80°C
- Ambient temperature range: 0-40°C
- Ambient humidity range: 35-85% RH

Outline

4. Part names

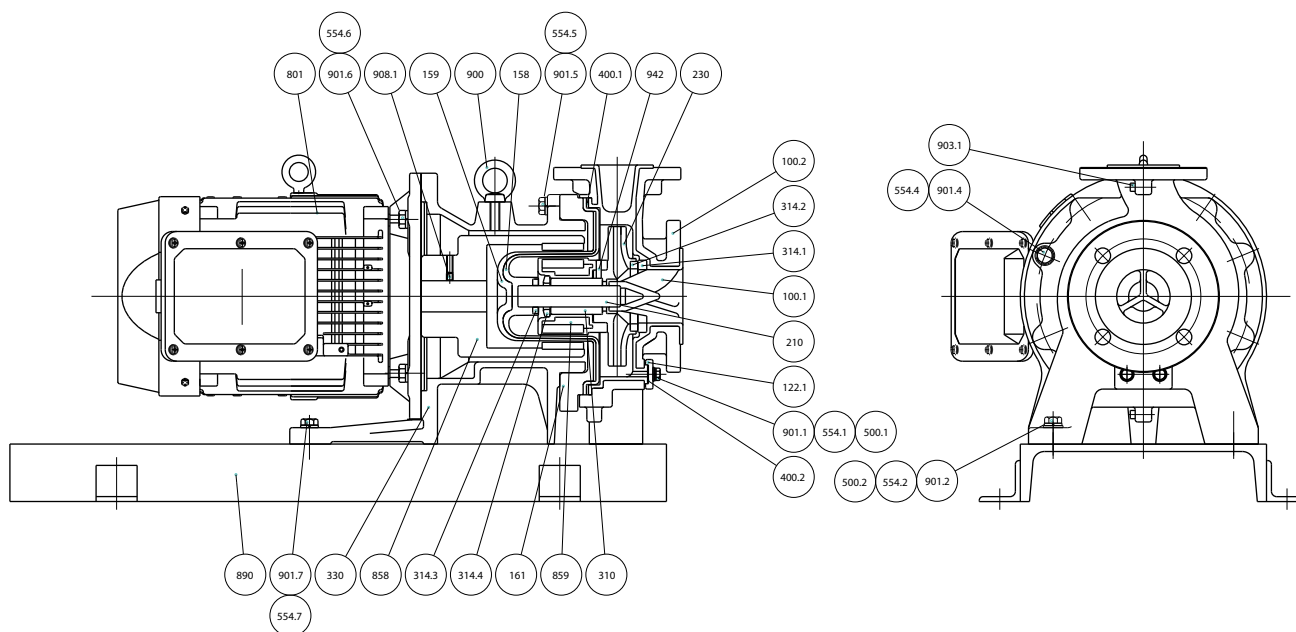

NO.	Parts name	Q'ty	NO.	Parts name	Q'ty
100.1	Front casing	1	554.2	Spring washer	2
100.2	Cover	1	554.4	Spring washer	8
122.1	Drain plate	1	554.5	Spring washer	4
158	Rear casing	1	554.6	Spring washer	4
159	Rear casing cover	1	554.7	Spring washer	2
161	Rear casing support	1	801	Motor	1
210	Spindle	1	858	Drive magnet unit	1
230	Impeller	1	859	Magnet capsule unit	1
310	Bearing	1	890	Base plate	1
314.1	Liner ling	1	900	Eye bolt	1
314.2	Mouth ring	1	901.1	Hex. head bolt	2
314.3	Rear thrust ring	1	901.2	Hex. head bolt	2
314.4	Rear ring	1	901.4	Hex. head bolt	8
330	Bracket	1	901.5	Hex. head bolt	4
400.1	Gasket	1	901.6	Hex. head bolt	4
400.2	Drain gasket	1	901.7	Hex. head bolt	2
500.1	Plain washer	2	903.1	Hex. head bolt	5
500.2	Plain washer	2	908.1	Hex. socket set screw	2
554.1	Spring washer	2	942	Pin	2

See the construction drawing for details.

Installation

<i>1. Before installation</i>	<i>10</i>
<i>2. Piping.....</i>	<i>11</i>
<i>3. Wiring</i>	<i>14</i>
<i>4. Protection equipment.....</i>	<i>14</i>

Installation

1. Before installation

Example of recommended piping

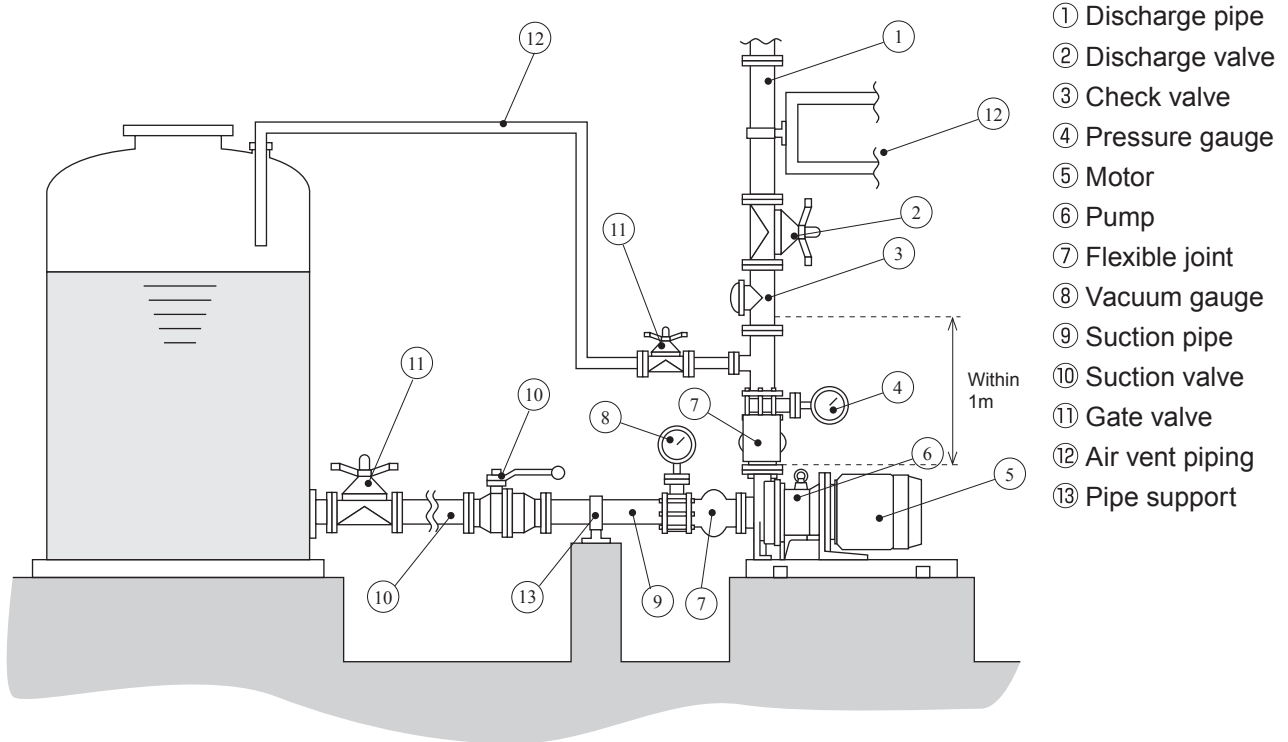

1. Installation location

- The pump should be installed on a flat foundation where is free from vibration or torsional force.
- Spacing for the motor removal (for back pull out) and maintenance (assembly and dismantlement) are needed.
- Installation surface should be larger than the pump base.

2. Positioning

- Install the pump as close to the suction tank in flooded suction system.
- If the flooded suction system can not be realized, install the auxiliary piping for priming and a foot valve at the suction pipe end.

3. Pump mounting

- See the diagram below for mounting the pump in the foundation.
- For the pump without the base plate, note that the pump can not be dismantled with the foot supports of the cover and bracket fixed in the foundation.

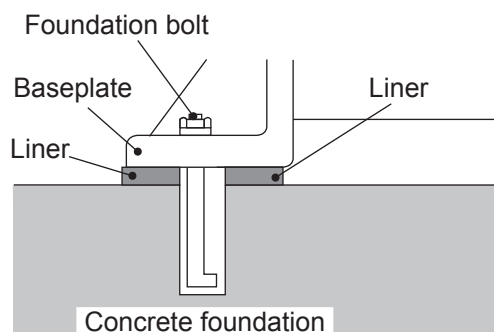

Installation

2. Piping

■ Tightening torque between discharge/ suction ports and pipes

Connections between the pipes and the pump ports should be tightened according to the table below.

Tightening torque (RV)

Bolt size	Tightening torque
M16	78.4 N•m

■ Piping load and momentum

The permissible piping weight and moment to the pump are as below.

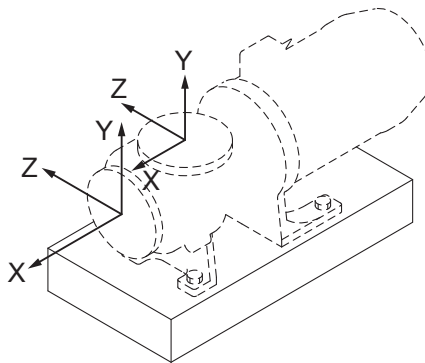

Permissible stress to the pump flange

Load direction	Load kN	
	Discharge flange	Suction flange
	AMP 40 & 50	AMP 40 & 50
F _x	0.71	0.89
F _y (Contraction/Tension)	0.89/0.44	0.58
F _z	0.58	0.71

Permissible moment to the pump flange

Load direction	Moment kN · m	
	Discharge flange	Suction flange
	AMP 40 & 50	AMP 40 & 50
M _x	0.35	0.46
M _y	0.46	0.35
M _z	0.23	0.23

Installation

■ Suction piping

1. *Flooded suction system*

Always realize the flooded suction system. Avoid the suction lift system.

2. *Suction piping bore*

Suction piping bore should be larger than pump inlet.

3. *Shortest piping length*

Have the piping short as much as possible with the minimum number of bends.

4. *Straight pipe length*

The piping end right before the pump inlet should be straight.

When the pump inlet bore is 50A or smaller, the straight pipe length should be of 500 mm or longer

When the pump inlet bore is 65A or larger, the straight pipe length should be eight times longer than inlet bore. For the easy pump removal and maintenance, install a removable pipe of 300mm in straight piping.

5. *Air pocket*

Do not make any projection or arch-shaped in piping where air may be trapped along the suction piping.

The suction pipe should have an ascending gradient of 1/100 toward the pump.

6. *Use of the eccentric reducer pipe*

If the pump inlet bore is different from that of suction pipe, use the eccentric reducer pipe. Upper side should always be level. The air may be trapped if it is mounted upside down.

7. *Gate valve installation*

In flooded suction, a gate valve should be installed on the suction piping for easier overhaul & inspection.

8. *Flushing piping*

Install the flushing piping for cleaning the pump when handling a harmful liquid.

9. *Suction piping end*

The suction piping end should always be at least 500 mm lower than a liquid level for the prevention of the air ingress.

10. *In suction lift system*

- The distance between the end of suction piping and the bottom of a suction tank should be 1 to 1.5 times larger than the suction pipe bore.

- Be sure to install a foot valve or a check valve on the suction piping.

11. *Piping support*

Support piping by pipe supports so that the pump is not subject to piping weight or thermal stress.

12. *Connections*

Each connection must be secured so that the air can not be sucked in. Imperfect sealing can cause the air ingress and it results in the insufficient suction and the seizure of bearing.

Installation

■ Discharge piping

1. Discharge piping bore

When the discharge piping is long but the piping bore is equal to the pump outlet bore, the specified performance may not be obtained because pipe resistance becomes high. Calculate pipe resistance in advance to decide a discharge piping bore.

2. Discharge valve installation

Install a discharge valve on the piping about 1m away from the pump. The air bleed piping should be provided near the discharge valve in order to prevent the air from remaining.

3. Gate valve installation

Install a gate valve on the discharge piping to adjust flow rate and to protect the motor from overload. If a check valve is installed, the recommended installation order is : Pump → Check valve → Gate valve.

4. Pressure gauge

A pressure gauge is required on the discharge piping to check operating conditions such as discharge capacity and head.

5. Check valve

A check valve is required in the following cases.

- Discharge piping length is between 15 and 20 meters.
- Actual head is higher than 15 meters.
- The distance between the liquid level in the tank and the top end of discharge piping is 9 meters or more.
- Two pumps run in parallel.

6. Air vent

Install an air vent on the discharge piping when the horizontal piping length is between 15 and 20 meters.

7. Drain

Install a drain valve when draining of liquid is required (to protect the pump from freezing, etc.).

8. Piping support

Support the piping by pipe supports so that the piping weight does not totally weigh the pump.

9. Priming piping

The piping for priming is required on the discharge piping in suction lift system.

Installation

3. Wiring

Electrical works or wiring must be carried out by a qualified person according to local laws or regulations.

- Use the electromagnetic switch which conforms to the motor specifications of voltage and capacity etc.
 - When installing the pump out of doors, take a measure to prevent rain water from getting into the switch when wiring.
 - Install the electromagnetic or the push-button switch apart from the pump.
 - The star-delta starter, inverter, or soft starter is recommended to start the motor of 5.5kW or more.
- * See the instruction manual of the motor manufacturer for the motor detail.

4. Protection equipment

It is recommended to install the following monitoring devices in order to protect the pump.

1. Current sensor/ Power sensor The sensors monitor the motor load and stop the pump on the detection of load change, giving an alarm.
2. Pressure sensor The sensor monitors the starting pressure and stops the pump on the detection of pressure change, giving an alarm.
3. Flow sensor The sensor monitors the discharge flow and stops the pump on the detection of flow change, giving an alarm.
4. Level sensor The sensor monitors the liquid level and stops the pump when it falls below the specified level, giving an alarm.

It is recommended to install two or more monitoring devices. The more monitoring devices, the more possibility of protecting the pump.

The DR series dry running protector (electric current sensing type) is also available as an option. Contact us for detail.

Operation

<i>1. Before operation</i>	<i>16</i>
<i>2. Operation</i>	<i>17</i>
<i>3. Shutdown</i>	<i>17</i>

Operation

1. Before operation

CAUTION

- Never run pump dry or run pump with a suction side valve closed. Otherwise the pump fails in a short period.
- Check the rotational direction of the pump. Clockwise seen from the motor end is correct direction. Operation in the reverse direction may cause pump damage. Always carry out rotation check with the pump full of liquid.
- Stop the pump within one minute if cavitation occurs.
- Do not run the pump while it is sucking the air through the suction port.
- Stop the pump within one minute when the magnet coupling is disconnected. The magnet force reduces if the pump keeps on running in this condition.
- The maximum number of ON/OFF operation should be within six times an hour. Frequent ON-OFF operation can reduce the pump life.
- Keep liquid temperature change within 80°C through operation and stopping.
- Start the pump with a discharge valve full close in order to avoid water hammer.
- Closed-discharge operation should be within one minute. If the pump runs with a discharge valve closed for a long time, the liquid temperature inside the pump rises and it damages the pump.
- If power is interrupted when the pump is running, switch off and close discharge valve.
- Take extra care so that the discharge pressure dose not exceed the pump limit.
- When high temperature liquid is transferred, the pump surface becomes very hot. Take a protective measure against burn. See below.

Liquid temperatuer	Surface temperature
80°C	75°C

- Noise level is 90dB (A scale - one meter)
In case the pump noise affects human health or the communication to secure a safety, provide a noise reduction cover. Be careful not to reduce cooling effect by a motor fan.

Operation

2. Operation

1. Fully close a discharge valve and fully open a suction valve.

2. Prime the pump.

- If the pump is in flooded suction system, fully open both discharge and suction valves.
- If the pump is in suction lift system, prime the suction piping as well as the pump.

3. Check rotating direction of the motor.

- Close a discharge valve. Power the motor for a quick moment (within a second) in order to check the rotation direction. A correct direction is shown with "arrow" mark on the pump (Clockwise seen from motor fan side).
- Check if the motor fan smoothly stops when it is powered off.

NOTE: If the motor does not stop smoothly, check rotating parts.

4. Air elimination

- Before full operation, eliminate the air in the pump.
- Fully open the valve on the air bleed piping. Run the pump for one second and repeat it 3 to 5 times for air elimination.
- After the air elimination, fully close the discharge valve.

NOTE: In case air bleed piping is not equipped, repeat the momentary run several times with a discharge valve open.

5. Starting operation

- Start the pump with a discharge valve fully closed. Stop the closed-discharge operation within one minute.
- Confirm that discharge pressure rises to the shut off pressure.
- Gradually open discharge valve to obtain the specified pressure (capacity).

NOTE: Pay attention to the over-load caused by an excessively opened valve.

Precautions on operation

1. Check for loose bolts on the pump. Retighten the rear casing support mounting bolts by the specified torque of 85N•m.

2. When the pump keeps running in negative rotation, the pump breaks.

3. Closed-discharge operation should be within one minutes.

4. Make sure that a flow rate is always equal to or more than the minimum one. The operation below the minimum flow can reduce the lubricant and cooling functions on the sliding parts. This could lead to failure. Minimum discharge capacity is 50 ℓ /min.

3. Shutdown

1. Slowly close a discharge valve.

Quick closing by a solenoid valve may cause water hammer and damages the pump. Be sure to slowly close any discharge valve.

2. Switch off and stop the pump.

Check that the pump stops smoothly. If the pump stops roughly, inspect it.

NOTE: When leave the pump stopped for a long period, take a countermeasure against freezing for the prevention of freeze in the pump and piping. In case a blackout interrupts the pump operation, switch off the pump and close discharge valves.

Maintenance

<i>1. Troubleshooting</i>	<i>19</i>
<i>2. Maintenance & Inspection</i>	<i>21</i>
<i>3. Disassembly & Assembly.....</i>	<i>23</i>
<i>4. Spare & Wear parts.....</i>	<i>29</i>

Maintenance

1. Troubleshooting

Troubles	Symptom		Cause	Check & Countermeasures	
	When a discharge valve is closed.	When a discharge valve is opened.			
Liquid can not be discharged.		The readings of pressure/vacuum gauges vibrate and drops to zero.	<ul style="list-style-type: none"> The pump is not primed enough. Dry running 	<ul style="list-style-type: none"> Stop the pump. Prime the pump and restart operation. 	
	The pump can not be primed.		<ul style="list-style-type: none"> The foot valve is clogged with foreign matters. 	<ul style="list-style-type: none"> Clean the foot valve. 	
	After starting, the pressure drops as a discharge valve is opened.		The readings of pressure/ vacuum gauges vibrate and drops to zero.	<ul style="list-style-type: none"> The air ingress through the suction pipe end or gasket. 	<ul style="list-style-type: none"> Check if suction pipe-work connections are completely sealed. Check if liquid level of the tank is not too low.
				<ul style="list-style-type: none"> A disconnection of the magnet coupling 	<ul style="list-style-type: none"> Check if the motor is not overloaded by checking amperage. Check if foreign matters do not lock the impeller or magnet capsule. Check if voltage is normal.
Pressure gauge keeps showing low pressure.			<ul style="list-style-type: none"> Low pump speed The pump rotates in reverse. 	<ul style="list-style-type: none"> Check wiring or motor. Correct wiring. 	
Discharge capacity is too low.	Pressure & vacuum are normal.	Vacuum is high.	<ul style="list-style-type: none"> The strainer is clogged with foreign matters. 	<ul style="list-style-type: none"> Remove foreign matters. 	
		Vacuum is very high.	<ul style="list-style-type: none"> Air pocket in suction piping 	<ul style="list-style-type: none"> Check and correct suction piping. 	
			<ul style="list-style-type: none"> Foreign matters are clogged at impeller inlet. 	<ul style="list-style-type: none"> Remove foreign matters. 	
		The readings of pressure gauge & vacuum gauge vibrate.	<ul style="list-style-type: none"> Air ingress from suction pipe or gasket. 	<ul style="list-style-type: none"> Check connections on piping and retighten as necessary. 	
			<ul style="list-style-type: none"> Discharge piping clogs with foreign matters. 	<ul style="list-style-type: none"> Remove foreign matters. Remove foreign matters or scales in piping. 	
Vacuum gauge indicates high but pressure is normal.		<ul style="list-style-type: none"> There are resistance such as air pocket in suction piping. 	<ul style="list-style-type: none"> Check if there is no protruded section in suction piping. 		

Maintenance

Troubles	Symptom		Cause	Check & Countermeasures
	When discharge valve is closed.	When discharge valve is opened.		
Discharge capacity is too low.	Pressure & vacuum are normal.	Pressure is high but vacuum is normal.	• Actual head is too high or pipe resistance is too large.	• Check actual head of discharge piping and loss of pipe resistance.
	Pressure is low and vacuum is very low.	Pressure is low and vacuum is low.	• Motor rotates in reverse.	• Interchange motor wiring.
Motor is overheated.			• Power voltage is low.	• Check voltage or frequency.
			• Overload	• Check specific gravity and viscosity of liquid.
			• Ambient temperature is too high.	• Keep a good ventilation.
Discharge capacity is rapidly reduced.		Vacuum gauge indicates high figure.	• Suction piping clogs with foreign matters.	• Remove foreign matters.
Pump vibrates.			• Foundation is not perfect.	• Reinstall the pump.
			• Loose mounting bolts.	• Retighten the bolts.
			• Cavitation occurs.	• Remove the cause of cavitation.
			• The bearing is worn or melted.	• Replace as necessary.
			• Magnet capsule or spindle is broken.	• Replace as necessary.
			• Dynamic balance of drive magnet is upset.	• Remove the cause. Replace as necessary.
			• Motor bearing is worn.	• Replace bearing or motor.

Maintenance

2. Maintenance & Inspection

WARNING

- **Do not have the medical electronics close to magnet.**

Any person who is equipped with the medical electronic such as a pacemaker should not be close to the magnet of pump.

- **Pay attention to magnet force**

The magnet force is powerful. Take care not to catch the finger in metal parts.

■ Periodic inspection (Every six months)

Part names	Inspection items	Measures
Drive magnet unit	<ul style="list-style-type: none"> ● If there is a friction trace. ● If the drive magnet housing is correctly mounted or if the hex. socket set screws are not loosened. ● Decentering of the magnet and motor shaft (Max.1/10mm). 	<ul style="list-style-type: none"> ○ If abnormality is found, contact us. ○ Remount the drive magnet to motor shaft or retighten the set screws. ○ Retighten the hex. socket set screws or replace the drive magnet (Contact us for replacement.).
Rear casing	<ul style="list-style-type: none"> ● If there is a friction trace in inner surface. ● If there is a crack on wet-end material. ● If the rear thrust ring is worn. ● If the inside is dirty. 	<ul style="list-style-type: none"> ○ If abnormality is found, consult us. ○ Replace as necessary. ○ If it is worn, contact us. ○ Clean the inside.
Magnet capsule	<ul style="list-style-type: none"> ● If there is a friction trace on surface. ● If there is a crack on surface. ● Measure the bearing inner bore. ● If the impeller is secured to the magnet capsule. 	<ul style="list-style-type: none"> ○ If abnormality is found, contact us. ○ If abnormality is found, contact us. ○ Replace it if it is worn beyond the wear limit. ○ If it is loose, replace or contact us.
Impeller	<ul style="list-style-type: none"> ● Measure the mouth ring thickness. ● If there is a crack. ● If there is a cavitation trace. (Abnormality related to the mouth ring such as wear and seizure.) ● If the impeller is not clogged. ● If the impeller is deformed. 	<ul style="list-style-type: none"> ○ Replace as necessary. ○ Replace as necessary. ○ Remove the cause of cavitation. ○ Remove clogs. ○ Replace as necessary.
Front casing	<ul style="list-style-type: none"> ● Wet-ends are dirty. ● If there is a crack. ● If there is an abnormal wear, crack and friction trace on liner ring. ● If drain is clogged. ● If gasket is swelled or O ring is cracked. ● If there is a friction trace. 	<ul style="list-style-type: none"> ○ Clean them. ○ Replace as necessary. ○ Contact us if abnormality is found. ○ Clean the drain. ○ Replace as necessary. ○ Contact us.
Spindle	<ul style="list-style-type: none"> ● If there is a crack. ● If the bearing is worn beyond the limit. 	<ul style="list-style-type: none"> ○ Replace as necessary. ○ Replace as necessary.
Rear casing support	<ul style="list-style-type: none"> ● If the rear casing support mounting bolts are not loose. 	<ul style="list-style-type: none"> ○ Retighten the bolt by the specified torque. ○ When a frequent ON-OFF operation is made or liquid temperature fluctuates, retighten the bolt periodically.

Maintenance

■ Wear limits of bearing and spindle

Model	Bearing inner diameter		Spindle outer diameter	
	Before use	Wear limit	Before use	Wear limit
AMP40-1, AMP50-1	26	27	26	25

1. The values on the table shows wear limit at each part.
2. If the clearance between the inner diameter of the bearing and the outer diameter of the spindle exceeds 1 mm, either the bearing or spindle, whichever has greater wear, should be replaced regardless of the wear limit.

Carbon bearing (CF) type: Normally the carbon bearing will be replaced first.

SiC bearing (KK) type : Replace the bearing and spindle at the same time.

3. Sliding parts may suffer initial wear in an initial operation phase but this is not abnormal.

■ Wear limit of mouth ring

The step between the surfaces of the mouth ring and the impeller is 2 mm before use. When the step becomes 0 mm, replace the mouth ring.

Model	Thickness of mouth ring	
	Before use	Wear limit
AMP40-1	8 mm	6 mm
AMP50-1	9 mm	7 mm

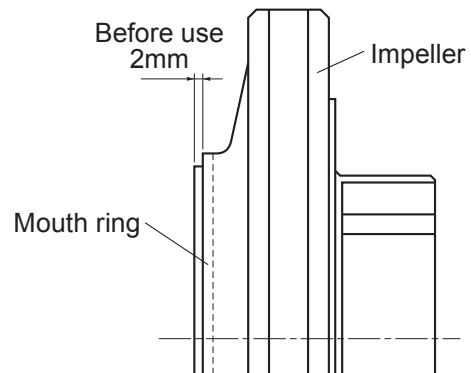

Maintenance

3. Disassembly & Assembly

WARNING

- **Pay attention to magnet field**

The magnet drive pump has a pair of strong magnets. The strong magnet field could adversely affect the persons who are assisted by electronic devices such as the pacemaker.



- **Do not catch the finger**

The magnet force of the pump is powerful. Take care not to catch the finger in the bracket.



- **Wear protective clothing**

Coming in contact with a harmful chemical liquid may cause eye or skin trouble. Wear protective clothing such as a protective mask, goggles, gloves during the work.



- **Turn off power during the maintenance work**

Risk of electrical shock. Make sure the power source is turned off, and the pump and devices are stopped prior to the work.



CAUTION

- **Pay attention to magnet force**

The magnet force is powerful. Take care so that iron pieces and iron powder do not stick to the magnet of pump.

- The powerful magnet force can break the data of the magnetic card, disc or so. Do not have the magnetic product close to the magnet of pump.

Tool list

Following tools are necessary to disassemble and assemble the pump.

Tool	AMP40-1, AMP50-1	Remarks
Spanner	13 mm, 19 mm, 24 mm	1 pc/each
Hex. wrench	4 mm, 5 mm	1 pc/each
Plastic round bar	34 mm dia. × 100 L	To remove & mount bearing
Plastic welder or industrial dryer	1 unit	
Hand press	1 unit	
Plastic hammer	1 pc	

Maintenance

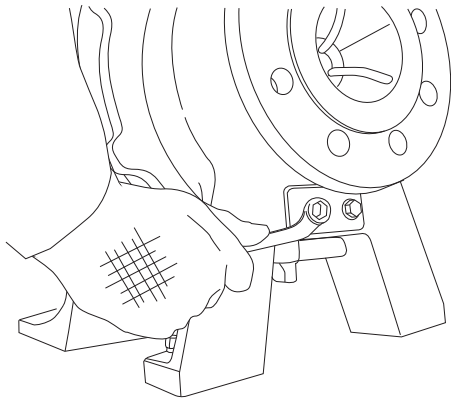

■ Pump casing disassembly

1. Remove the hex. bolts (901.3) and drain plate (122.1) to drain liquid out of the pump unit.

For the pump model without drain, neutralize the liquid or flush the pump unit out. And then remove liquid by dismantling the pump or pipework.

⚠ WARNING

If the hex. bolts are loosened at once, liquid may fly off, resulting in personal injury.

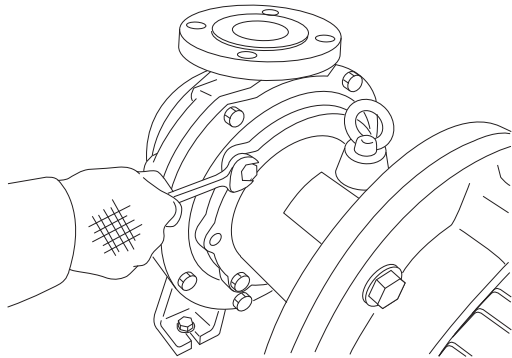

2. Remove two mounting hex. bolts (901.7) on the foot support.

3. Remove four pump unit mounting hex. bolts (901.5) on the bracket (330).

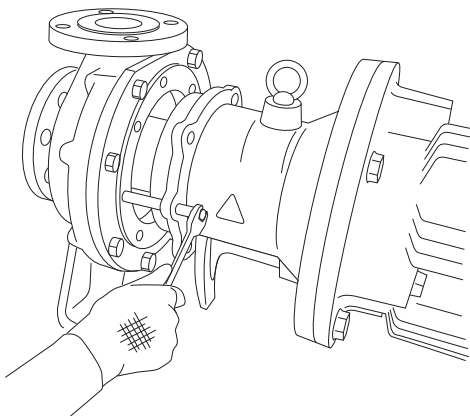

4. Pull the motor backward by alternatively screwing in the two bolts (M12×100: for back pull out). Screw in the bolts by approximately 80 mm.

5. Pull out the motor with bracket, lifting it by the crane. Draw the motor out straight so that the drive magnet (858) does not come in contact with the rear casing (158).

Keep the motor balanced when it is lifted up.

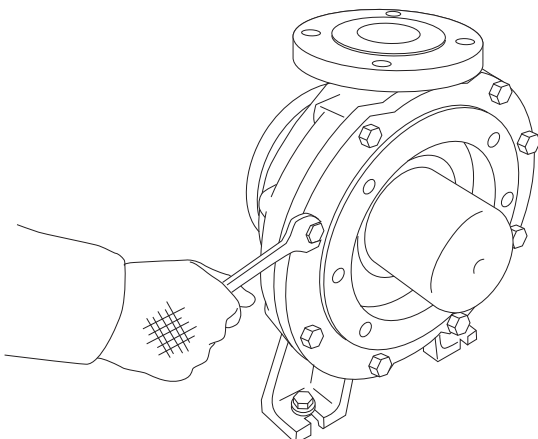

6. Unscrew the hex. bolts (901.4) which is fixing the rear casing support to the cover (100.2) and then remove the rear casing support.

NOTE: The rear casing and the rear casing cover may be removed together with the rear casing support.

Be careful not to drop the impeller (230)/magnet capsule (859) unit from the rear casing.

Maintenance

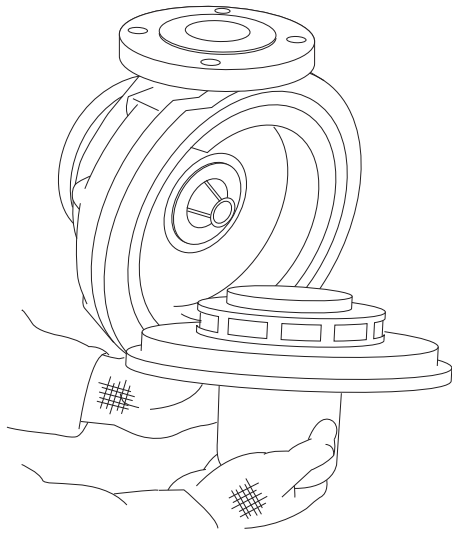

7. Remove the rear casing cover (159) from the rear casing (158). Be careful not to drop the impeller (230)/ magnet capsule (859) unit from the rear casing. When the rear casing can not be removed from the rear casing support, hit the bottom of the rear casing to detach it.

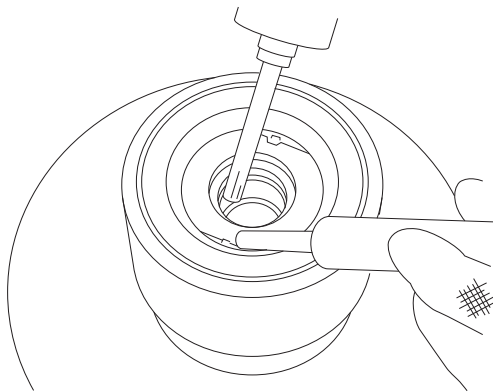

■ Removal of the impeller and bearing

1. Heat the lugs on the rear ring (314.4) by a plastic welder or industrial dryer and open the lugs up.
2. Warm the impeller assembly in the hot water of 80°C. If it is not warmed up enough, the bearing or the rear ring may break.

! Wear protective clothing for the prevention of scald.

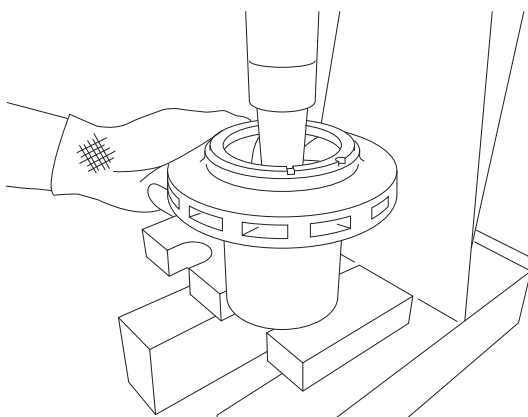

3. Apply the plastic round bar (34 mm dia. 100L) to the impeller-side bearing end and then push out the bearing (310) and rear ring (314.4) by the hand press.

Maintenance

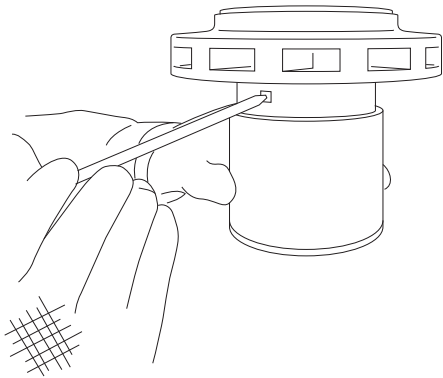

4. Push off the pin (942) by the screw driver.

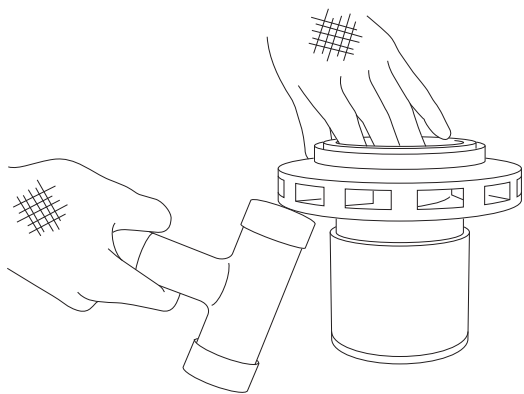

5. Remove the impeller (230) from the magnet capsule (859). If the impeller can not be removed, hit the impeller back lightly with the plastic hammer.

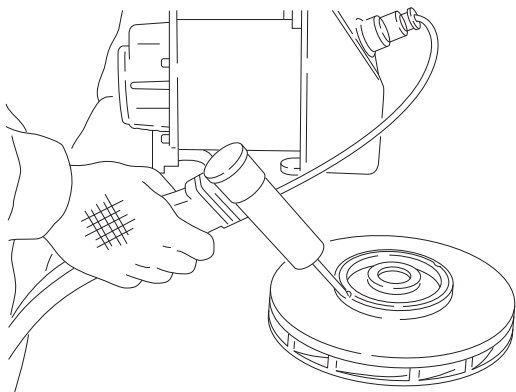

■ Mouth ring replacement

1. Heat the lugs on the mouth ring by a plastic welder or industrial dryer and open the lugs up.

2. Warm the impeller in the hot water of 80°C and then replace the mouth ring (314.2) with new one.

❗ Wear protective clothing for the prevention of scald.

3. Heat the lugs on the mouth ring by a plastic welder or industrial dryer and then close the lugs down.

Maintenance

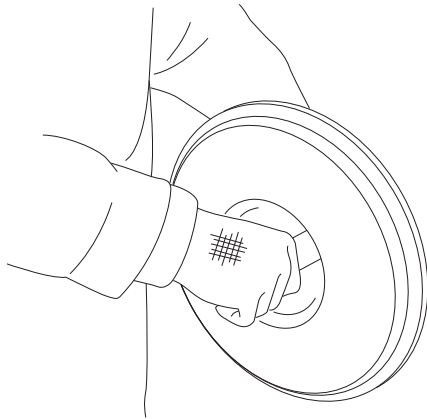

■ Spindle replacement

1. The spindle (210) is slightly pressed into the rear casing (158). Pull the spindle out by the hand.

Warm the rear casing in hot water if the spindle can not be pulled out. Then pull the spindle out by lightly moving it from side to side and up and down. The rear thrust ring (314.3) comes off as the spindle is removed.

- ❗ Wear protective clothing for the prevention of scald.

2. Clean the insertion part of the spindle. Fit the rear thrust ring in the rear casing with no interference to the spindle insertion. Press the spindle into place by the hand or the hand press.

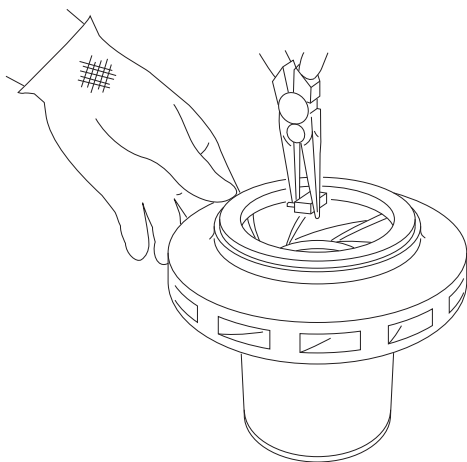

■ Impeller/ Bearing mounting

1. Fit the impeller into the magnet capsule, mating the insert ports of the pin.

Note that the mated connection of the impeller and the magnet capsule need to be machined. We have all the impeller machined in advance.

2. Insert the pin. Use pliers for easy insertion.

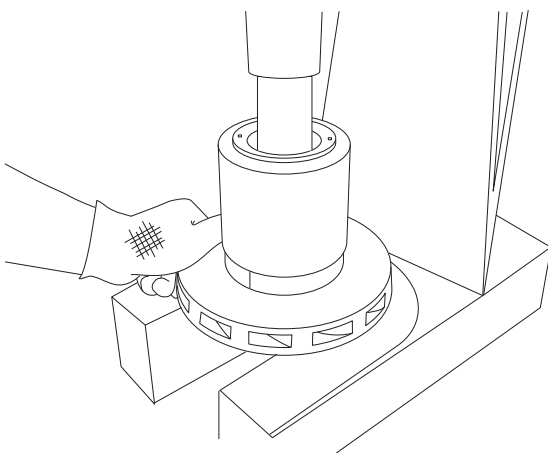

3. Turn the magnet capsule upside down with the impeller fitted. Warm the magnet capsule in the hot water of 80°C. after it is warmed, press the bearing into the magnet capsule by the hand press.

- ❗ Check that the pin is fully inserted and there is no interference during press fitting.

- ❗ Wear protective clothing for the prevention of scald.

4. Insert the rear ring. Heat the lugs on the mouth ring by a plastic welder or industrial dryer and then close the lugs down.

Maintenance

■ Assembly

Assembly can be made in reverse procedures to disassembly. Pay attention to the following points.

Gasket replacement

Always replace the gasket with new one every time the pump unit is assembled. Do not twist or catch the gasket in the parts. Clean the sealing surfaces before mounting.

Tightening of bolts

Tighten the bolts diagonally and evenly.

Cleaning magnet capsule

Waste metal such as Iron pieces can be attracted to the magnet capsule. Remove such foreign matters before assembly.

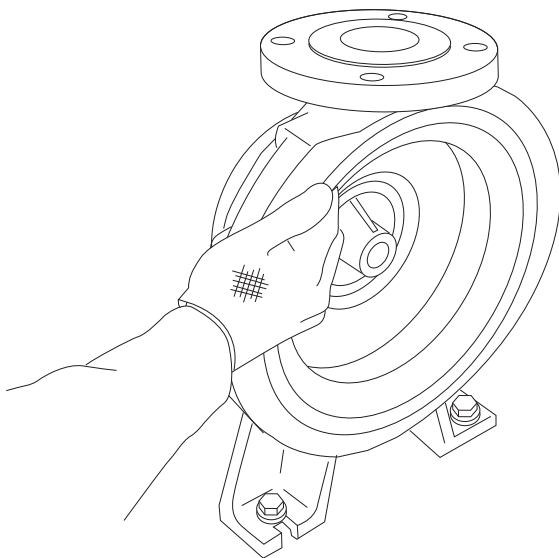

1. Place the gasket in the front casing (100.1).
2. Put the impeller assembly in the rear casing. Fit the rear casing together with the impeller assembly, rotating the rear casing right and left.
3. Mount the rear casing cover and the rear casing support. And then tighten the rear casing support mounting hex. bolts by 85N•m diagonally and evenly.

NOTE: Loose the bolts (901.7) on the foot support before retightening the rear casing support mounting bolt.

4. Remove foreign matters from the drive magnet on the motor shaft.
5. Screw the two bolts (M12×100: for back pull out) in the bracket half way. Direct the motor bracket to the pump unit parallel.
6. Slowly close the motor to the pump unit by alternatively unscrewing the two bolts (M12×100: for back pull out).
Fit the motor straight to the pump unit so that the drive magnet (858) does not come in contact with the rear casing.
Fix the bracket and the rear casing support by mounting hex. bolts.

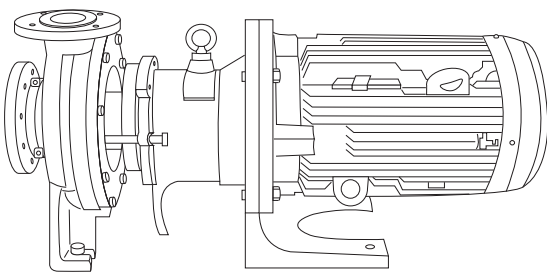

! After assembly, retighten the rear casing support mounting bolts.

Maintenance

4. Spare & Wear parts

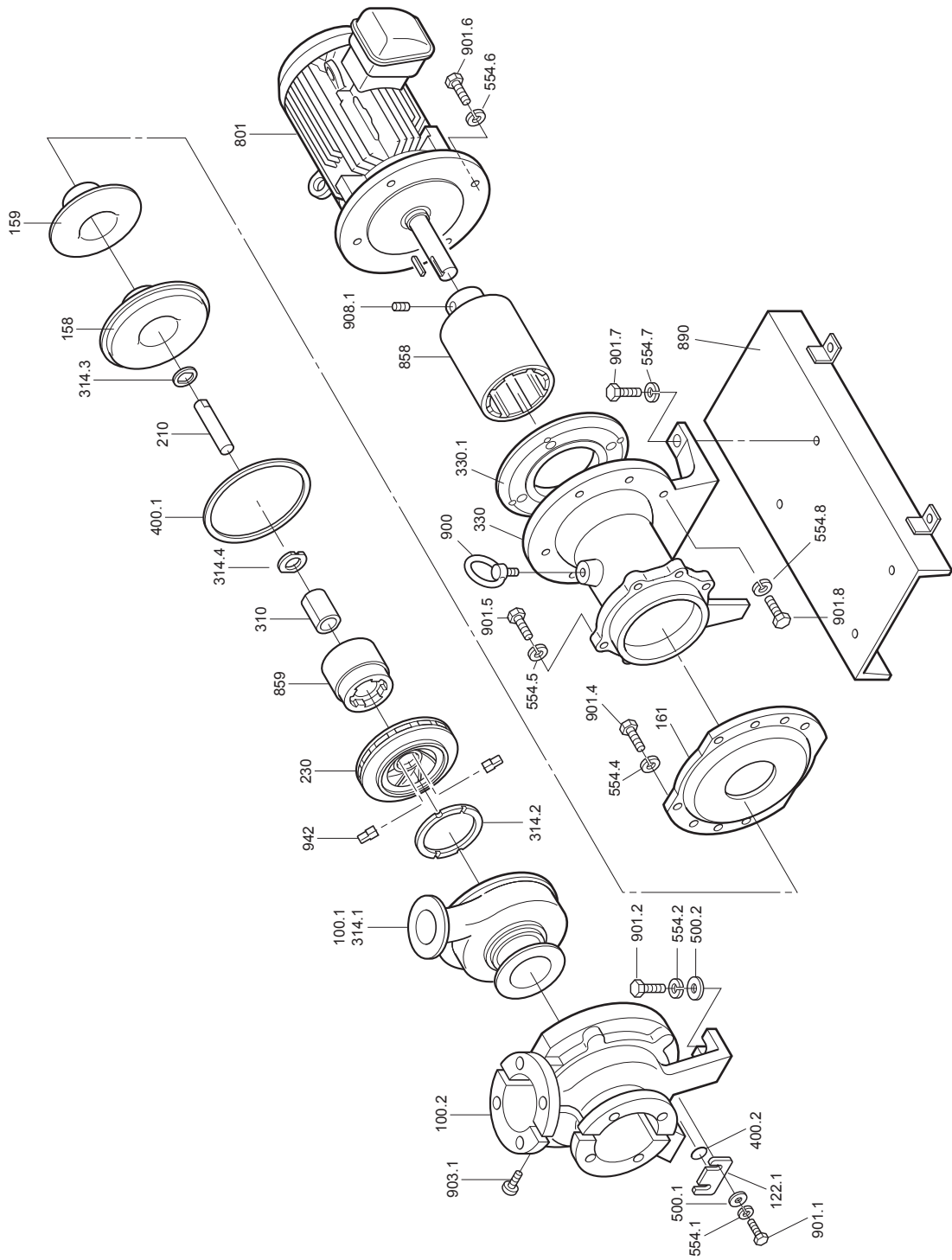

Maintenance

**Always stock spare parts, especially wear parts, for a long period of continuous operation.
Contact us with the following items when placing an order for spare parts.**

1. Part name and part number (See the exploded view.)
2. Model code and MFG.No (See the nameplate)
3. Drawing number (If you have an approved drawing.)

No.	Part names	ID	Material	Reference code	
				AMP40J/40A	AMP50J/50A
210	Spindle	CF	Alumina ceramic 99.5%	AMP0012	AMP0012
		KK	SiC	AMP0013	AMP0013
310	Bearing	CF	High density carbon	AMP0014	AMP0014
		KK	SiC	AMP0015	AMP0015
314.2	Mouth ring	CF	PTFE (with filler)	AMP0016	AMP0055
		KK	SiC	AMP0017	AMP0056
314.3	Reat thrust ring		PTFE	AMP0018	AMP0018
400.1	Gasket, Casing		PTFE	AMP0024	AMP0024
400.2	Gasket, Drain		PTFE	AMP0025	AMP0025

Assembly parts are also available. Contact us for detail.

**IWAKI PUMPS**<http://www.iwakipumps.jp>□ **IWAKI CO.,LTD.** 6-6 Kanda-Sudacho 2-chome Chiyoda-ku Tokyo 101-8558 JapanTEL:(81)3 3254 2935 FAX:3 3252 8892(<http://www.iwakipumps.jp>)

()Country codes

Germany	: IWAKI EUROPE GmbH	TEL : (49)2154 9254 0	FAX : 2154 1028	Australia	: IWAKI Pumps Australia Pty. Ltd.	TEL : (61)2 9899 2411	FAX : 2 9899 2421
Italy	: IWAKI Italia S.R.L.	TEL : (39)02 990 3931	FAX : 02 990 42888	Singapore	: IWAKI Singapore Pte. Ltd.	TEL : (65)6316 2028	FAX : 6316 3221
Denmark	: IWAKI Nordic A/S	TEL : (45)48 24 2345	FAX : 48 24 2346	Indonesia	: IWAKI Singapore (Indonesia Branch)	TEL : (62)21 690 6606	FAX : 21 690 6612
Sweden	: IWAKI Sverige AB	TEL : (46)8 511 72900	FAX : 8 511 72922	Malaysia	: IWAKIm Sdn. Bhd.	TEL : (60)3 7803 8807	FAX : 3 7803 4800
Finland	: IWAKI Suomi Oy	TEL : (358)9 2742714	FAX : 9 2742715	Taiwan	: IWAKI Pumps Taiwan Co., Ltd.	TEL : (886)2 8227 6900	FAX : 2 8227 6818
Norway	: IWAKI Norge AS	TEL : (47)66 81 16 60	FAX : 66 81 16 61	Thailand	: IWAKI (Thailand) Co.,Ltd.	TEL : (66)2 322 2471	FAX : 2 322 2477
France	: IWAKI France S.A.	TEL : (33)1 69 63 33 70	FAX : 1 64 49 92 73	Hong Kong	: IWAKI Pumps Co., Ltd.	TEL : (852)2 607 1168	FAX : 2 607 1000
U.K.	: IWAKI PUMPS (UK) LTD.	TEL : (44)1743 231363	FAX : 1743 366507	China	: IWAKI Pumps (Guandong) Co., Ltd.	TEL : (86)750 380 9018	FAX : 750 380 9078
Switzerland	: IWAKI (Schweiz) AG	TEL : (41)26 674 9300	FAX : 26 674 9302	China	: GFTZ IWAKI Engineering & Trading (Guangzhou)	TEL : (86)20 8435 0603	FAX : 20 8435 9181
Austria	: IWAKI (Austria) GmbH	TEL : (43)2236 33469	FAX : 2236 33469	China	: IWAKI Pumps Co., Ltd. (Beijing)	TEL : (86)10 6442 7713	FAX : 10 6442 7712
Holland	: IWAKI Holland B.V.	TEL : (31)297 241121	FAX : 297 273902	China	: IWAKI Pumps (Shanghai) Co., Ltd.	TEL : (86)21 6272 7502	FAX : 21 6272 6929
Spain	: IWAKI Iberica Pumps, S.A.	TEL : (34)943 630030	FAX : 943 628799	Philippines	: IWAKI Chemical Pumps Philippines, Inc.	TEL : (63)2 888 0245	FAX : 2 843 3096
Belgium	: IWAKI Belgium n.v.	TEL : (32)1367 0200	FAX : 1367 2030	Korea	: IWAKI Korea Co.,Ltd.	TEL : (82)2 3474 0523	FAX : 2 3474 0221
U.S.A.	: IWAKI America Incorporated	TEL : (1)508 429 1440	FAX : 508 429 1386	Vietnam	: IWAKI Pumps Vietnam Joint Venture Co.,Ltd.	TEL : (84)613 933456	FAX : 613 933399

T667-3 '08/05